

Discussion

Proposed method for dolomite land hazard and risk assessment in South Africa

D B Buttrick (Visitor), A van Schalkwyk (Visitor), R J Kleywegt (Visitor), R B Watermeyer (Fellow) in *Journal of the South African Institution of Civil Engineering*, 43(2) 2001:27–36

N Trollip, Engineering Geologist – Dolomite Stability Unit, Council for Geoscience:

One of the greatest benefits to come out of the introduction of the National Home Builders Registration Council (NHBRC) is the interaction between the various professionals resulting from the need to ensure acceptable development risk on dolomite. This interaction has been lacking for years, perhaps because (engineering) geologists and (structural and civil) engineers do not always speak a common language. As an aside: of particular concern is the fact that more universities are moving away from making insight into geology a prerequisite for engineering students, a move which is most certainly to lead to even further 'communication shortfalls'.

For the past 40 years, the Council for Geoscience (CGS) has played a role in ensuring that residential development on dolomite has been properly planned so that the integrity of the subsurface materials are not negatively affected and that its condition is maintained in perpetuity. This function has been rather one-sided in that a geological report was produced, the CGS commented on the dolomite related risk, recom-

mendations were made and the CGS report comment then represented the end of the line with regards to geologically related input. There was no coordinated interaction between the planners, developer, engineers, local councils and the CGS before, during and after construction. Since 1 December 1999 this has changed dramatically.

The NHBRC procedure, contained in the Home Building Manual, now ensures the involvement of the engineering geologist right up to the construction (completion) phase. This added exposure (of the geologist and the CGS) to development has certainly presented many eye-openers, the most significant being the misconceptions regarding dolomite risk on the part of some engineers and the functions of the foundation types on the part of some geologists. Although some professionals are more than capable in the other discipline, many professionals fail to interact adequately. This has been borne out most prominently by engineers responding to the request to design for a small to medium size sinkhole by asking: Is it really that bad? The NHBRC-stimulated interaction

has and will hopefully continue to allow professionals to set aside misunderstandings through dialogue and arrive at better solutions which in turn benefit the home building industry.

Much discussion among dolomite stability investigators has centred on the issue of D2 and D3 designation. A long-standing struggle was the fact that the Home Building Manual indicated that D3 constituted a foundation in/on an enhanced earth mattress. This brought about confusion for very shallow dolomite sites where the mattress solution is not ideal (yet a better solution than the D2 design is needed). The geologist must ensure that the design will not fall short of the anticipated risk! This problem has to a certain degree been bridged by the modification presented in the 2001 paper by Buttrick *et al*, which alludes to the reinforced concrete grid spanning from pinnacle to pinnacle (proposed by Wagener) and other solutions. As it was/is beyond the scope of the paper, the issue of foundation solutions for D3 was not discussed. It would, however, be of great benefit if the authors could elaborate on this topic.

The authors:

INTRODUCTION

The paper focused on the deductive process that needs to be followed in order to arrive at the four Dolomitic Area Designations (see table 7 of the paper) that describe the necessary precautionary measures required to prevent the concentrated ingress of water into the ground on sites underlain by dolomites. In terms of this classification system, no precautionary measures are required in areas designated as being D1 and no houses may be constructed in areas designated as being D4. Areas designated as being D2 and D3 require such precautionary measures. However, areas designated as being D3 require precautionary measures in addition to those pertaining to the concentrated ingress of water into the ground.

Nicole Trollip's request for discussion on foundation solutions for D3 sites is very pertinent, as housing consumers and the NHBRC can be exposed to unacceptable risks should the 'precautionary measures, in addition to those pertaining to the concentrated ingress of water into the ground' required in sites designated as

being D3, not be correctly executed, or be misinterpreted. Even more so, the designer/competent person may be found negligent should a catastrophic event lead to an inquest and the practice followed by the professional be found to be deficient.

As the discussion centres on housing, the authors have confined their discussion to appropriate solutions for housing developments. For simplicity, the authors have confined the discussion to single-storey houses.

UNDERSTANDING THE PROBLEM

Sinkholes can occur at any point under or adjacent to the footprint of a structure. Apron slabs, which are commonly used to mitigate the effects of differential heave on structures and to move collapse settlements away from the footprint of the structure, have little effect on the location of a sinkhole. Accordingly, sinkholes having an Inherent Risk Characterisation (ie the chance for a certain size sinkhole or doline to occur within the postulated scenario of land use and dewatering or

non-dewatering) of 'high' as described in terms of table 6 of the paper can be expected to occur anywhere within the footprint of the structure. It must, however, be stressed that high-stand densities in areas of Medium Inherent Risk (Class 4) may change the Development Risk (ie likelihood and extent of loss of life, loss or damage to property or financial loss) from 'acceptable' to 'unacceptable', if mitigating measures are not implemented. These measures include special water precautionary measures and/or founding measures.

In order to maintain an Acceptable Development Risk, houses must either be designed to safely withstand the effects of sinkholes having an inherent risk characterisation of 'high' occurring anywhere under the footprint of the structure as indicated in figure 1 or measures need to be taken to reduce the risk of such sinkholes from occurring.

Dolines, on the other hand, occur where the premature termination of sinkhole formation occurs, or where the overburden material consolidates due to dewatering. Dolines that are due to the premature termination of sinkhole formation may be dealt with in the same man-

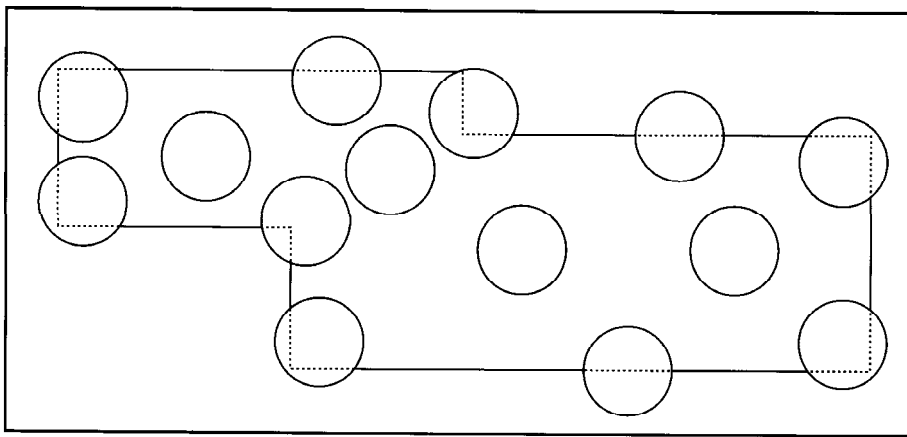

Figure 1 Critical locations of sinkholes under the footprint of a house

Table 1 Performance requirements for houses

Description	User needs	Performance description
Structural safety	The risk of collapse or other kind of severe damage resulting from structural failure, which may affect the life safety of the dwelling occupants or people in the vicinity of the building, shall not exceed a level acceptable to the user	The capacity of the whole house and its parts, with an appropriate degree of reliability, to maintain their strength and stability under all actions likely to occur during its design life
Structural serviceability	The structural behaviour of a house, under normal use and condition, that may affect: <ul style="list-style-type: none"> • the efficiency and appearance of the house and its components • the functioning of the occupants and the equipments in the house, and • the comfort of the occupants is to be kept at a level acceptable to the users 	The performance description is the ability of the whole house and its parts, with an appropriate degree of reliability, to perform adequately for normal use under all expected actions. It can be described in terms of: <ul style="list-style-type: none"> • local damage (including cracking) (which may affect the efficiency and appearance of the house and its components) • unacceptable deformation (which may affect the efficient use or appearance of the house or the functioning of the people and equipment) • excessive vibration (which may cause discomfort to people or affect the functioning of the people and equipment)

ner as sinkholes. Accordingly, for the purpose of this discussion, only dolines resulting from the consolidation of the overburden will be discussed.

Dolomite risk management may require that areas of shallow groundwater levels are described as D3, although such areas may in their present state be low-risk areas. If the groundwater level is inadvertently lowered, doline formation may be generated if the original water level is located above bedrock in soil materials with a low dry density, high void ratio and high Compression Index.

Sites with dolines of this nature will only be encountered in Class 5 sites, ie where the water table is above the dolomite bedrock in soil material with low dry density, high void ratio and high compression index. In such circumstances, houses situated at the perimeter of the doline will be subject to differential settlements.

PERFORMANCE REQUIREMENTS FOR HOUSES

The draft ISO standard for Houses – Description of Performance (ISO 15928) establishes user needs and performance descriptions with respect to structural safety and structural serviceability in houses (see table 1). As indicated in table 1, performance levels need to reflect what is acceptable to the user.

The Joint Structural Division's Code of Practice for Assessment of the Performance of Housing Units in South Africa (2000) identifies a number of structural design considerations. These may be stated as follows:

1 In areas where a sinkhole can occur, its size must be such that it will not completely envelop a house or result in the toppling or sliding failure of a house into such a hole.

2 There must be sufficient time for occupants to escape from the house after the occurrence of a sinkhole.

3 Damage to the house after the occurrence of a sinkhole must be within acceptable limits.

Considerations 1 and 2 relate to structural safety whereas consideration 3 relates to structural serviceability. Consideration 1 effectively precludes the development of detached houses where the risk of medium sinkholes (2–5 m), large sinkholes (diameter of between 5 to 15 m) and very large sinkholes (greater than 15 m) is 'high'.

It should be noted that a high development density in a Class 4 area may result in a D3 designation rather than the usual D2 designation in order to maintain an 'Acceptable' Development Risk.

The risk of collapse or other kind of severe damage resulting from structural failure due to the loss of foundation support arising from sinkhole formation or severe differential settlement attributable to doline formation can be readily assessed using structural engineering principles. This can be done by assuming a loss of support equivalent to the diameter of a nominated sinkhole (2,0 m in Class 5 sites and 5,0 m in Class 3 and 4 sites which are designated as being D3) occurring anywhere under the footprint of a house or the likely magnitude of the differential settlement to which a house may be subjected to at the extremity of a doline. Thus the abovementioned Joint Structural Division's design considerations relating to safety can be readily assessed.

The damage to the structure after the occurrence of a sinkhole must, however, also be considered. In South Africa, most houses are of masonry construction. Accordingly, only this form of construction will be considered in this discussion.

Watermeyer and Tromp (1992) introduced the concept of expected damage (approximation of the probable damage) in respect of masonry walls and concrete slab construction. The description of a range of categories of expected damage for masonry walls and concrete floors are presented in tables 2 and 3, respectively. The allowable deflection ratios used in the design of foundations to attain a category of expected damage no more severe than category 1 are tabulated in table 4 (Joint Structural Division 1995).

The Joint Structural Division's code of practice (1995) requires that damage resulting from movements within near surface soil horizons (ie swelling, shrinkage, collapse settlement and consolidation) should not be more severe than that associated with category 2. The code does, however, recommend that category 1 damage be designed for where houses are subject to movements associated with heaving clays. The National Home Builders Registration Council have adopted these recommendations and have framed their standards around these levels of expected damage. The Joint Structural Division's code of practice

Table 2 Categories of expected damage with respect to masonry walls (after Watermeyer & Tromp 1992)

Category and degree of expected damage	Description of damage in terms of ease of repair and typical effects
Minor damage – categories 0 to 2	
0 Negligible	Hairline cracks less than about 0,25 mm width are classed as negligible
1 Very slight	Fine internal cracks which can easily be treated during normal decoration. Cracks rarely visible in external masonry
2 Slight	Internal cracks easily filled. Redecoration probably required. Recurrent cracks can be masked by suitable linings. Cracks not necessarily visible externally. Doors and windows may stick slightly
Significant damage – categories 3 to 5	
3 Moderate	Cracks can be repaired and possibly a small amount of masonry may have to be replaced. Articulation joints may have to be cut in some of the walls. Doors and windows sticking. Rigid service pipes may fracture. Weather-tightness often impaired. Up to 10 mm gap between ceiling cornices and walls
4 Severe	Extensive repair work which includes breaking out and replacing sections of walls, especially over doors and windows, cutting of articulation joints in walls and the construction of moisture trenches and apron slabs around the structure, or the jacking of foundations, depending on the type of soil movement. Window and door frames distorted, floor sloping noticeably, some loss of bearing in beams. Service pipes probably disrupted. Up to 20 mm gap between ceiling cornices and walls
5 Very severe	Major repair work required, involving partial rebuilding and the abovementioned repair techniques. Beams lose bearing, walls tilt badly and require shoring. Windows broken and distorted. Danger of instability

Table 3 Categories of expected damage with respect to concrete floors (after Watermeyer & Tromp 1992)

Category and degree of expected damage	Description of typical damage
Minor damage – categories 0 to 2	
0 Negligible	Hairline cracks, insignificant tilt of floor or change in level
1 Very slight	Fine but noticeable cracks. Floor reasonably level
2 Slight	Distinct cracks. Floor noticeably curved or changed in level
Significant damage – categories 3 to 5	
3 Moderate	Wide cracks. Obvious curvature or change in level – local deviation of slope from the horizontal may exceed 1:100
4 to 5 Severe to very severe	Gaps in floor. Disturbing curvature or change in level



Figure 2 Recent 'medium' sinkhole in a high-density residential development

(2000), however, requires that damage in areas underlain by dolomites should not be more severe than that associated with category 4. This level of expected damage is consistent with the aforementioned safety requirement that there must be sufficient time for occupants to escape from the structure after the occurrence of a sinkhole.

Serviceability requirements are based on acceptable performance under normal day-to-day loadings (eg gravity loads, wind loads, seismic loads, temperature, etc), issues of appearance, protection of the interior of housing units from the elements, and, in some instances, human comfort. There is a point of diminishing return when it comes to the prediction of probable property damage. For a given cost, a certain level of probable property damage reduction is attained. It then becomes a problem of economics to weigh the present value of the investment costs against the cost of future property losses and the loss of the use of the property. Moreover, the problems of economics must be placed in a probabilistic framework, since the losses are associated with a natural hazard that has a probability of occurrence.

The following fundamental questions need to be answered before proceeding with any engineering solution:

- What level of expected damage must be designed for in respect of sinkholes and dolines?
- What are the implications and costs associated with the repairing of a sinkhole?

Figure 2 illustrates the extent of a medium sinkhole in a high-density residential development

ENGINEERING SOLUTIONS

Geotechnical solutions

Geotechnical solutions improve the material on the plan area of the development by

- the removal of unsuitable material and replacement with selected, compacted granular fill
- the removal of material and return of same with controlled compaction in layers, or
- in-situ compaction by methods such as dynamic consolidation

In this way, the highly variable material is improved to form a mattress of known strength and suitable thickness below the structure. This mattress of soil not only reduces differential settlements but improves the impermeability of the material overlying the sensitive, unstable dolomite and hence reduces the risk of sinkhole and doline formation occurring beneath the structure. It also forms a relatively competent roof over any small- and medium-sized cavities that may form below the structure.

Table 4 Allowable deflection ratios to limit expected damage to that of Category 1 (Joint Structural Division 1995)

Type of masonry	Allowable deflection ratio	
	Unreinforced	Lightly reinforced
Hogging movements		
Articulated masonry		
• plastered	1:800	1:600
• face	1:650	1:500
Full masonry		
• plastered	1:2000	1:1250
• face	1:1500	1:1000
Sagging movements		
Articulated masonry		
• plastered	1:500	1:500
• face	1:350	1:300
Full masonry		
• plastered	1:1000	1:500
• face	1:500	1:300

Table 5 Classification according to average thickness of overburden (Wagener 1981)

Class	Description
A	Pinnacle and boulder dolomite overlain by moderately thick overburden ($c < 3$ m)
B	Pinnacle and dolomite overlain by moderately thick overburden ($3 \text{ m} \leq c \leq 15$ m)
C	Pinnacle and boulder dolomite overlain by thick overburden ($c > 15$ m)

c = the average thickness of the overburden to tops of pinnacles and boulders

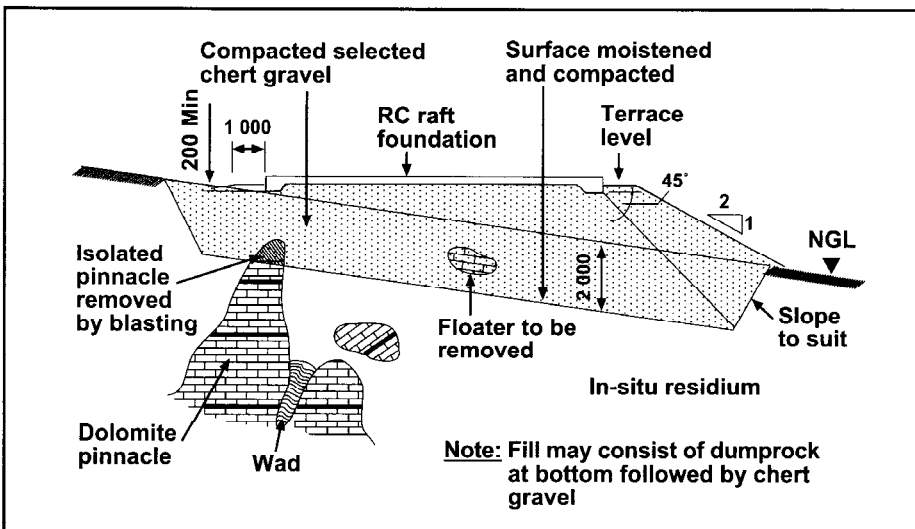

Figure 3 Mattress on a class B or C site (thick cover over pinnacles and boulders) (Wagener 2002)

The thickness of the mattress will depend on a number of factors, the most important being (Wagener 2002)

- the thickness and properties of the soil overlying pinnacles and boulders
- the properties of the in-situ soil below the mattress, and
- the sensitivity of the proposed structure to settlement

The mattress may be constructed using conventional equipment to excavate material and compact the fill or dynamic consolidation. The method of mattress construction is best determined after a number

of trenches (3 to 4 m deep) have been excavated and profiled to determine the thickness of soil cover over pinnacles and boulders as well as the nature of the material.

The stress distribution below a mattress approximates to a 45° load spread. This property is explored in the design of mattresses. (Wagener 1985, 2002). In class A sites (see table 5) the mattress tends to distribute the loads into the pinnacles by arching. In class B and C sites (see table 5), the mattress spreads the load to weaker underlying layers.

On class A sites (see table 5), where rockfill is available, the material is typically removed to a depth of about one

metre below tops of pinnacles and large boulders, and is backfilled with rockfill to about 200 mm above the pinnacles. Thereafter, the remainder of the terrace is constructed with selected chert gravel or other suitable granular material placed under controlled conditions (Wagener 1985, 2002). On class B and C sites, the thickness of the mattress is typically between 1,5 and 2,5 m in thickness. Slab-on-the-ground foundations, in accordance with the provisions of the Joint Structural Division's code of practice (1995), are most appropriate where mattresses are constructed as they are relatively shallow and distribute loads effectively. There is no point in providing a mattress and then excavating through it, to found the house.

It is difficult to construct mattresses on steeply sloping sites or for a house with the ground floor on different levels as the continuity of the mattress is compromised. In these instances consideration should be given to a suspended floor system resting on columns that are supported by stub columns or piles anchored into bedrock.

Structural solutions

Founding on pinnacles

Where abundant pinnacles occur in close proximity to the surface, they can be used as 'supports' for a reinforced concrete grid spanning from pinnacle to pinnacle. If support positions are required in between the pinnacles, these can sometimes be created using stub columns or piles anchored into bedrock.

Raft foundations

The following foundation types, designed in accordance with the provisions of the Joint Structural Division's Code of Practice for Foundations and Superstructures for Single Storey Residential Buildings of Masonry Construction, are suitable:

- stiffened raft foundations (grid of reinforced/ post-tensioned concrete beams cast integrally with the floor slab)
- stiffened strip footings (reinforced grouted cavity wall construction with interconnected floor slabs), or
- cellular raft foundations (two horizontal reinforced concrete slabs interconnected by a series of webs)

The raft should be designed to span over a 'soft spot' (loss of support) of a given diameter (see Holland 1981 and Joint Structural Division 1995).

Floor slabs should be reinforced and connected to or supported by all edge and stiffening beams. Failure to do so may result in slabs in small rooms toppling or sliding into sinkholes. Alternatively, slabs which are only supported on two sides at a corner, may collapse should a sink hole occur at a corner.

Table 6 Site class designations (Watermeyer & Tromp 1992)

Typical founding material	Character of founding material	Expected range of total soil movements (mm)	Assumed differential movement (% of total)	Site class
Rock (excluding mud rocks which may exhibit swelling to some depth)	Stable	Negligible	–	R
Fine-grained soils with moderate to very high plasticity (clays, silty clays, clayey silts and sandy clays)	Expansive soils	< 7,5	50%	H
		7,5–15	50%	H1
		15–30	50%	H2
		> 30	50%	H3
Silty sands, sands, sandy and gravelly soils	Compressible and potentially collapsible soils	< 5	75%	C
		5–10	75%	C1
		> 10	75%	C2
Fine-grained soils (clayey silts and clayey sands of low plasticity), sands, sandy and gravelly soils	Compressible soils	< 10	50%	S
		10–20	50%	S1
		> 20	50%	S2
Contaminated soils, controlled fill, dolomitic areas, landslip, landfill, marshy areas, mine waste fill, mining subsidence, reclaimed areas, uncontrolled fill, very soft silts/silty clays	Variable	Variable		P

Piled foundations

Piled foundations may also provide a viable solution under certain circumstances. Extreme care must, however, be taken in order to ensure that the piles are socketed into pinnacles or bedrock as opposed to floaters.

All pile foundations should be proof-drilled for a minimum of 6 m of solid rock.

RECOMMENDATIONS FOR HOUSING IN D3 SITES

It must be remembered that, in accordance with the addendum to the Joint Structural Division's code of practice (1998), sites need to be classified in terms of both the dolomitic area designations and site class, viz Class P (Dolomites – D3/x), where x is the symbol describing the founding characteristics. The recommendations given below are generally suitable for site class designations H, C, S, C1, S1 and C2 and, in some instances, site class S2 (see table 6).

Dolines

Stiffened strip footings or stiffened/cellular rafts with articulation joints or solid lightly reinforced masonry in accordance with the provisions of the Joint Structural Division's code of practice (1995) should be provided. (These solutions will be similar in nature to those for sites designated as being class S2. It will, however, not be possible to predict the axis through the structure about which the differential movements will take place.)

Split construction in accordance with the provisions of the Joint Structural Division's code of practice (1995) may also be provided. (This solution will be the same as that for sites designated as being class H2.)

The category of expected damage should be no more severe than category 2.

Sinkholes

Stiffened strip footings or stiffened or cellular rafts or reinforced concrete grids spanning from pinnacle to pinnacle with articulation joints or solid lightly reinforced masonry, in accordance with the provisions of the Joint Structural Division's code of practice (1995), should be provided for sites with an Inherent Risk Class of 5 (see table 6 of the paper). The design criteria should be that the foundations withstand a loss of support over an area having a diameter of 2,0 m, occurring anywhere under the footprint of the house, and restrict damage in such an event to that associated with category 2 expected damage. (These solutions will be similar or slightly more substantial than sites designated as being class C2, as the code's design criteria for such sites is that the minimum dimension of soft spots occurring beneath the house, in the most adverse location, should not be less than 1,5 m.)

An alternative solution, on sites with an Inherent Risk Class of 5, is the installation of a soil mattress as described by Wagener (1985, 2002) and to provide a foundation system placed on top of the mattress, capable of withstanding a loss of support over an area, occurring anywhere under the footprint of the house, having a diameter in metres of

- 2,0 with the damage associated, with such an event not being more severe than category 4 expected damage, and
- 2,0 minus twice the thickness of the mattress below the base of the perimeter foundations, with the damage associated with such an event not being more severe than category 2 expected damage

A slab-on-the-ground foundation, in accordance with the provisions of the Joint Structural Division's code of practice, constructed on top of the mattress with three additional Y12 bars being placed in the top of the perimeter edge beam, satisfies the above criteria if the overall thickness of the mattress is not less than 1,3 m.

In low-cost housing developments, where the cost of repairing a sinkhole is large in proportion to the value of the house, it is recommended that the abovementioned mattress and slab-on-the-ground-foundation solution be adopted.

Where sites having an Inherent Risk Class of 3 or 4 are classified as being D3 because of subsurface conditions or stand densities, it is recommended that soil mattresses as described by Wagener (1985, 2002) be installed to mitigate the effects of the subsurface conditions or stand densities. In such instances, it is recommended that the foundation system placed on top of the mattress be capable of withstanding a loss of support over an area, occurring anywhere under the footprint of the house, having a diameter in metres of

- 3,0, with the damage associated with such an event not being more severe than category 4 expected damage, and
- 5 minus twice the thickness of the mattress below the base of the foundations, with the damage associated with such an event not being more severe than category 2 expected damage

Although it is possible to design rafts to withstand the effects of 5,0 m 'soft spots' (see Holland 1981) by providing only a structural solution, it is not considered to be an appropriate solution. The cost and problems associated with the making good of a sinkhole, should it occur, far exceed any potential savings that would be made by opting for a structural solution over a geotechnical solution.

The authors do not recommend the construction of relatively small, detached, low-cost houses on sites having an Inherent Risk Class of 3 or 4 that are classified as being D3. In theory such developments can take place on sites having an Inherent Risk Class of 5. It must, however, be borne in mind that the cost of making good a 2 m diameter sinkhole on these sites is disproportionate to the value of these houses. Accordingly, it is recommended that relatively small, detached, low-cost houses, which are underlain by dolomites, should only be developed on Class 3 and 4 that are designated as being D2 sites.

In conclusion, the authors would like to stress that although there are geotechnical and structural solutions to reduce the risk of sinkhole formation in sites having an Inherent Risk Class of 3 or 4 that are classified as being D3, planners and engineers should realise that develop-

ment density on dolomite must be kept low. The costs and benefits of high-density developments on such land must be carefully considered.

Acknowledgements

The authors wish to acknowledge the valuable contributions made by Andre Fullard, Brian Lewis, Alistair Morgan, Bryan Tromp, Isak Venter and Fred Wagenaar in the formulation of this discussion.

References

Joint Structural Division 1995. Code of Practice for Foundations and Superstructures for Single Storey Residential Buildings of Masonry Construction. SAICE/IstructE.

Joint Structural Division 1998. Addendum to Code of Practice for Foundations and Superstructures for Single Storey Residential Buildings of Masonry Construction: Areas Underlain by Dolomites. SAICE/IstructE, May.

Joint Structural Division, 2000. The assessment of the performance of Housing Units in South Africa.

SAICE/IstructE, June.

Holland, J E 1981. The design, performance and repair of housing foundations. Civil Engineering Department, Swinburne Institute of Technology, Melbourne, Australia, November.

National Home Builders Registration Council 1999. Home Building Manual, Parts 1, 2 & 3, Revision 1, February.

Wagener, F von M 1981. Engineering evaluation of dolomitic areas. Seminar on the engineering geology of dolomite areas. Department of Geology. University of Pretoria.

Wagener, F von M 1985. Dolomites. *Civ Eng SA*, vol 27, July.

Wagener, F von M 2002. Engineering solutions in D3 dolomite areas. *Proceedings* of the Seminar on geotechnical aspects of the NHBRC Guidelines. Geotechnical Division, 27 May.

Watermeyer, R B & Tromp, B 1992. A systematic approach to the design and construction of single-storey residential masonry structures on problem soils. *The Civil Engineer in South Africa*, March.