

Postulates on shear in reinforced concrete

M Gohnert

Ambiguities associated with shear in reinforced concrete have led to a misunderstanding of what shear is and how it affects structural members. This paper therefore explores the notion of shear, using mechanics and finite elements as a tool to describe this force. A series of postulates are also presented in order to define the nature and characteristics of shear. The theory is then applied to structural elements such as beams and slabs. Various shear concepts, such as shear enhancement, shear in slabs and punching shear are also examined.

INTRODUCTION

An understanding of shear seems to elude many practitioners and researchers alike. Some even question the existence of shear. For those who research shear, testing and attaining a shear failure is difficult to achieve. Matching shear failure with theoretical models is nearly an impossible task. Furthermore, the complexity and uncertainty associated with shear has led to conservative code equations and is therefore an uneconomical feature of structural design (Kong & Evans 1987). Perhaps our problem lies in the fact that our analysis methods are based on linear-elastic models; yet, our codes are based on limit state principals. This mismatch, for the sake of making the design process practical, has led to confusion and a disparity between theory and observed shear failures.

The purpose of this paper is to explore

what shear is, using mechanics as a tool to describe this force. A set of postulates is proposed for the purpose of formally defining the characteristics of shear and its effects on reinforced concrete. The theory is then applied, with the help of finite elements, to various structural elements such as beams and slabs. Concepts such as shear enhancement, shear in slabs and punching shear are also considered and explained.

FUNDAMENTALS OF SHEAR

To understand shear, the internal forces within a structural member must be broken down into fundamental postulates. The first postulate states:

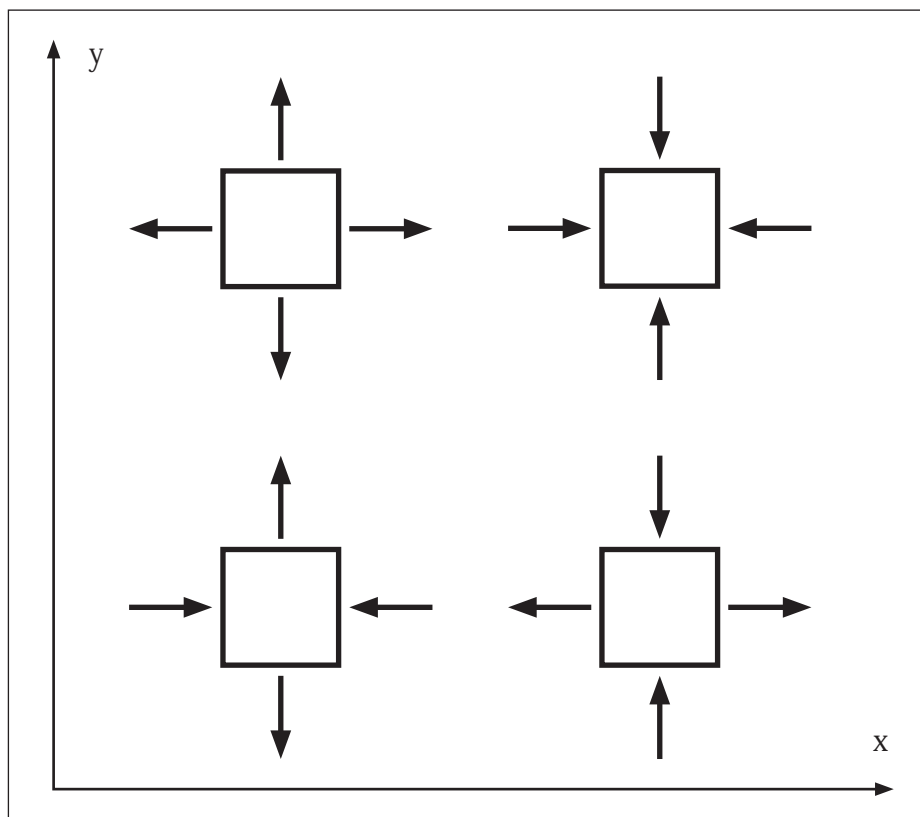

Figure 1 Various combinations of principal tensile and compressive stresses



PROFESSOR M GOHNERT received his BSc in civil engineering in 1985 and a master's of engineering management in 1987 from Brigham Young University, USA. In 1995, he received a PhD in civil engineering from the University of the Witwatersrand (Wits). He has worked for various companies in the United

States and in South Africa as a structural engineer. In 1990, he joined the School of Civil and Environmental Engineering at Wits University, where he is currently head of the school.

Contact details:

School of Civil and Environmental Engineering
University of the Witwatersrand
Private Bag X3
PO Wits, 2050
T 011-717-7125
gohnert@civil.wits.ac.za

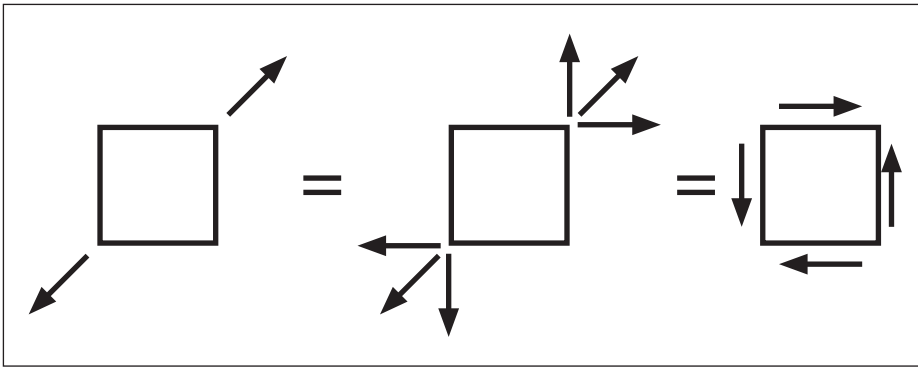

Figure 2 Shear stresses equivalent to components of tensile or compressive stresses applied at an angle

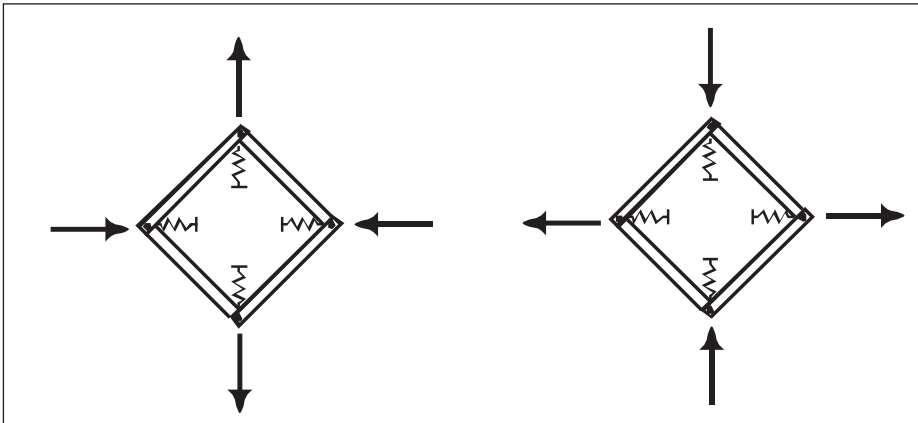

Figure 3 Pin-ended member used to model Poisson's effect of internal forces



Figure 4 Shear crack at end of beam

- 1 Only two fundamental forces exist in structural members – tensions and compressions

In structural members, there are three types of forces which include moments, shears and axial loads. These forces are in fact resultants (integrated stresses) which may be broken down into fundamental forces at a differential element level. Although we have specific nomenclature to describe these forces, all resultant forces comprise of tensions and/or compressions. A moment is merely a force couple, composed of tensions and compressions, caused by a linear or non-linear variation of stress across a section. An axial stress is either compressive or tensile and therefore complies with the postulate. The question is whether or not shear is a tensile or compressive stress as postulated. The answer is neither. Shear stresses are, however, components of tensile and compressive stresses. Figure 1 illustrates four possible

- 2 Shear stresses are components of tensile and compressive stresses applied at an angle to the x and y axes

Furthermore, what we call pure shear is the case of stress applied at 45 degrees to the x and y axes (figure 2). If stress is applied at some other angle, the differential element would be composed of normal stresses as well as shears (Wang & Salmon 1985).

The second postulate could, perhaps, be incorporated with the first postulate. However, it is separated to illustrate that shear is not a unique force, but a tensile or compressive stress applied at an angle to the plane under consideration.

The third postulate states:

- 3 Two forces will always exist and orientated orthogonally to one another

This postulate is based on the premise that structural materials are compressible. Compressive materials adhere to Poisson's effect and therefore two forces will always exist at an element level, orientated orthogonally (Ferguson *et al* 1988). These two forces may be compressive or tensile.

Poisson's effect may be modelled by a pin-ended mechanism attached to springs, as shown in figure 3. The model illustrates how opposing forces (tensions and compressions) are produced in compressive materials – the model is not an indication of unit displacements.

Poisson's effects are well known – a stress applied in one direction will produce an opposite stress at 90 degrees. Since all structural materials are compressible, the postulate is applicable and valid.

The fourth postulate states:

- 4 Only two modes of possible failure exist – tension and compression

If only two forces exist, then it is only logical that only two failure mechanisms exist – tension and compression. If we consider structural members, rather than differential elements, buckling is the third possible mode of failure in steel structures. In concrete, however, buckling rarely occurs and modes of failure are typically tension and compression failures – tension failure being the most predominantly observed. The question is, does the postulate apply to what we call a shear failure?

In figure 4, a reinforced concrete beam was tested to failure. Cracking in the beam is visible, extending from the support towards the first load point. The observed failure line is often referred to as a shear crack. Literature has repeatedly described the mechanisms by which shear forces affect structures and how they are resisted once cracking in the concrete has occurred – dowel action, aggregate interlock, inter-

differential elements subjected to various combinations of principal tensile and compressive stresses, orientated along the x and y axes. Figure 1 is the conventional method of illustrating bi-axial principal stresses along the x and y axes. However, stress is not limited to the x and y directions, but may occur at any angle. Figure 2 illustrates a tensile force applied at the corners of an element, orientated 45 degrees from the x-axis. The tensile stress may be broken down into components of stress, as shown in the second element. The components of stress replace the tensile stress and are graphically represented in the third differential element. The stress pattern of the third element is what we call shear. Thus, a shear stress is a graphical representation of a tension or compressive stress applied at an angle to the differential element.

If the tensile stress applied to the corner of the element is replaced with a compressive stress, the resulting shear pattern is opposite to the former. Likewise, if stress is applied to the other two corners of the element, the same two possible shear patterns would result.

As seen, shear stresses are merely components of tensile or compressive stresses applied at an angle to the x and y axes. Figure 1 illustrates a principal stress condition, and by definition will have no shear stresses. However, if stress is applied at some angle to the x and y axes, figure 1 would also graphically include shear stresses. This leads to the second postulate, which has already been defined in the preceding discussion:

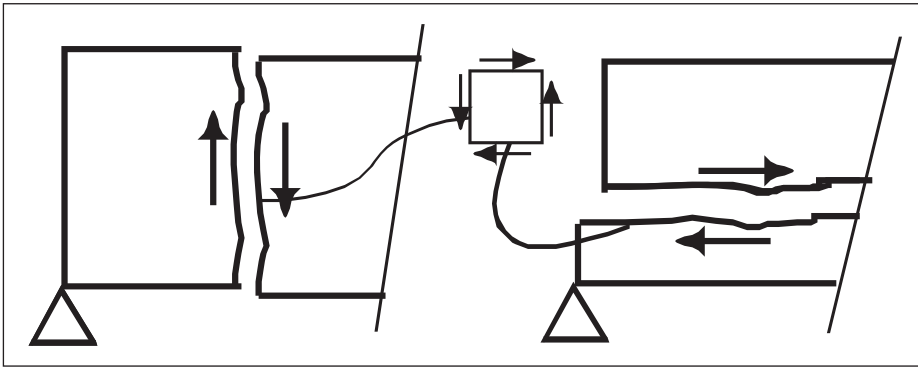

Figure 5 Vertical and horizontal modes of shear failure

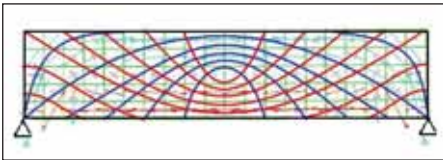

Figure 6 Principal stress pattern in a simply supported beam subjected to a UDL

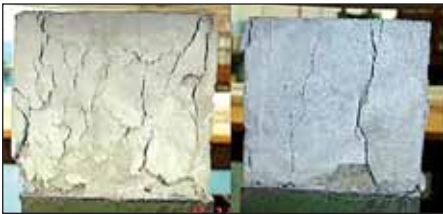

Figure 7 Predominant vertical failure lines in cubes

face shear transfer, etc (MacGinley & Choo 1990; Kong & Evans 1987). However, what we call a shear failure is not congruous with observed failure patterns. We are in fact misled by the term. Furthermore, shear theory assumes linear elasticity, which is not appropriate at the onset of cracking. The influence of the reinforcement on the crack pattern is also not taken into account.

Near the end of a simply supported beam, where shear is maximum and the bending moment is minimum, the stresses resemble the pure shear case illustrated in figure 2. The shear stresses are orientated vertically and horizontally which would precipitate failure patterns similar to those illustrated in figure 5 (Timoshenko 1970). The diagonal failure line in figure 4 is not vertical or horizontal, which would imply that the crack is not the result of shear forces. Furthermore, a shear failure would cause material slippage along the failure plane (translational failure); this was not observed. Cracking commenced at the bottom of the beam, propagating at an angle and terminating at a point near but falling short of the first load. Parallel slippage along the failure plane was not observed; the direction of crack displacement is perpendicular to the failure plane. This would imply that the observed failure is a tension failure rather than a shear failure.

Finite elements are used to illustrate the stress pattern in a beam. Figure 6 is an ABAQUS model of a beam composed of plane stress elements. The beam is simply

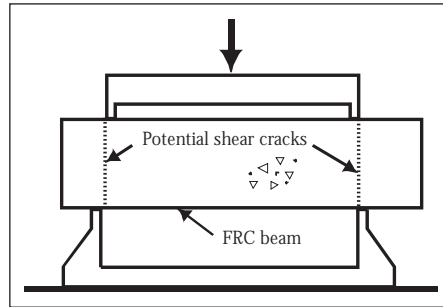

Figure 8 Shear test rig

supported and subjected to a uniformly distributed load. The plot illustrates the relative magnitude of the principal stresses as well as the orientation. Arrows pointing inward indicate a compressive stress and arrows pointing outward indicate a tension stress. The stress pattern exhibits catenary arching of the compressive forces (superimposed blue lines) as well as catenary sagging of tensile forces (superimposed red lines). Although tension stresses exist in the top corners of the beam, these stresses are negligible. The majority of tensile cracking occurs within the compression arch.

The plot clearly illustrates the region where tension stresses reside – along the bottom of the beam parallel with the span and curving upward near the supports. Cracks will form perpendicular to the orientation of these stresses matching the crack pattern of the test beam in figure 4. Thus, in the majority of cases, what are referred to as shear cracks are actually diagonal tension cracks which form consistently with the tension stress regions of the beam. This leads to the next postulate on shear:

5 *The shear and compressive strength of concrete is greater than the tensile strength*

Shear forces exist in concrete, but concrete rarely fails in shear. The reason is that concrete is an anisotropic material – the shear and compressive strength is greater than the tensile strength. Thus failures in concrete are primarily tensile.

The anisotropic nature of concrete is illustrated by compression tests on cube specimens. Although the stress field within

a cube is a complex arrangement of triaxial stresses and greatly influenced by friction between the contact surfaces, the failure lines are predominantly vertical rather than horizontal (figure 7) (Ferguson *et al* 1988). From postulate 3, a compressive stress applied in one direction will cause a tension stress orthogonally. The expansive tensile stresses in the horizontal direction are due to Poisson's ratio (the vertically applied compression will cause a horizontal tension). Since concrete is far weaker in tension than compression, the tension strength is reached prior to the compressive strength. Therefore tension cracks form along planes that are parallel to the compressive force. Ironically, what we call a compressive test is actually a measure of the tensile capacity of concrete.

There have been several attempts to devise a test to determine the shear capacity of concrete. Figure 8 is one such apparatus used to apply a pure shear condition to a concrete beam reinforced with steel fibre (JSCE No 3 1984). The theoretical failure plane is as illustrated – a shear failure line occurring between the faces of the applied load. The actual failure line, however, consistently forms at a slight angle between the centre of the applied force and the centre of the support. This mode of failure is not due to shear. The applied load flows directly into the support. The compressive force is increased until the tensile capacity is reached, at 90 degrees to the compressive thrust (postulate 3). Cracking of this nature is due to what is referred to as a splitting force (Ferguson *et al* 1988). Although the test is intended to determine the shear strength, the specimens consistently fail in tension. This example illustrates the difficulty in assessing the shear capacity of concrete for the simple reason – the shear capacity of concrete is greater than the tensile capacity.

Examples of failure lines are given in figure 9. As discussed previously, a shear mode of failure would require slippage along the failure plane. No slippage is discernible. The failure consists of a perpendicular separation of the concrete along the crack (indicative of tension) and some crushing of the concrete near the support.

The shear strength is greater than the tensile strength of concrete except in cases where a weak plane exists. This is a typical problem when dealing with composite members. A potential weak plane will exist between the two materials (ie, concrete on concrete or concrete on steel). Horizontal shear failure is common if the shear strength is reliant on chemical bonding. However, the horizontal shear strength is improved when the two materials are mechanically bound by reinforcement, shear studs or roughening the surface. Potential weak planes in reinforced concrete also exist along the length of the main steel. Thus some observed failure



Figure 9 Two examples of failure lines in shear tests

lines run parallel with the main steel in the regions of maximum shear.

It is interesting to note that what we call shear steel (vertical links) will resist shears running horizontally, but not vertically. From mechanics, the maximum shear stress on a cross-section is at the neutral axis. In a beam, this region is typically unreinforced horizontally and therefore susceptible to vertical shear cracking. Yet, vertical shear cracks are rare, except in some cases where the member is over-reinforced (this has been observed in tests where horizontal shear failure occurs along the main reinforcement and travels up vertically between the shear links to the first load point). Having said this, whether or not a beam is reinforced horizontally near the neutral axis is not a concern since the shear capacity of concrete is far greater than the tensile capacity. The purpose of the shear steel is not to resist shears, as the name would imply, but rather to resist inclined tensile forces near beam supports.

ENHANCED SHEAR STRENGTH NEAR SUPPORTS

Beams that are subjected to point loads near the supports exhibit what is referred to as enhanced shear strength (SABS 0100-1 2000; BS 8110: Part 1 1985; Rowe *et al* 1985). Tests seem to indicate that the shear capacity increases as the point load is placed closer to the end of the beam.

Enhanced shear capacity implies that the shear strength of the beam increases as the load is placed closer to the support (ie, an increase in v_c , which is a function of the concrete strength, quantity of the main tension steel and depth of the member). However, the area and spacing of the shear steel, the concrete strength and the depth of the beam usually do not vary; therefore the shear strength is constant from one end of the beam to the other. The term 'enhanced shear strength' is therefore misleading, since the shear capacity does not vary along the length of the beam.

An ABAQUS finite element solution is used to observe the flow of stresses with point loads placed at various distances from the face of the support. In figure 10a, a point load is placed at a distance $2d$ from the end of the support and in figure 10b the point load is placed at a distance d , where d is the distance from the compression face

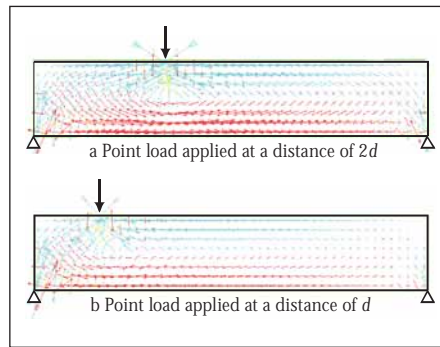

Figure 10 Stress distribution within a beam due to point loads

to the centre of the tension steel. The blue and the red lines indicate the magnitude and direction of the compression and tension stresses, respectively. A comparison of the two plots show that a point load placed further away from the support will cause more bending and thus flexural tensions in the bottom of the beam. The crack pattern is consistent with flexural failures. If the load is placed near the support, the load tends to flow directly into the support and will fail from splitting tension stresses orientated at right angles to the compression thrust; a diagonal failure line will form extending from the support to the point load (similar to the failure lines of figures 4 and 9).

From figures 10a and 10b it is observed that the flexural tensions are much greater than the splitting tensions for the same magnitude of load. Therefore, when the load is placed closer to the support, more load is required to produce a tensile stress sufficient to cause cracking. Thus the beam appears to increase in shear capacity, which is not the case. Again, a misnomer associated with shear.

SHEAR STRESSES IN SLABS

Shear in slabs

Another ambiguity with shear is why shear steel is not required in slabs if the calculated shear capacity is greater than the applied shear stress. This is contrary to other elements (ie, beams and columns) where shear steel is necessary regardless of the magnitude of the applied shear. There are several reasons: First, at working loads (linear elastic) the shear stress distribution along a vertical cross-section of a slab is parabolic in shape and the maximum shear is located at the neutral axis. Slabs are relatively thin and the main steel is in close proximity to the neutral axis, which will resist the shear stresses (or, more correctly termed – inclined tension stresses). In beams, the neutral axis is further away from the main steel and therefore this region is susceptible to failures associated with shear. Furthermore the main steel in slabs and beams has a dual function – the mid-span steel resists the flexural stresses and the steel at the ends resist the inclined tensions.

It is therefore imperative that the main steel extends beyond the edge of the support to provide anchorage in simply supported or continuous slabs. Leonhardt (1965) has also observed that because slabs have a greater a_v/d ratio ($a_v/d > 6$), slabs have a greater propensity to fail in flexure rather than shear (a_v is the distance from the application of the load to the centre of the support). Second, the flow of stress within a slab is low compared to beams and columns. A roof drainage system is an appropriate analogy. If the roof represents a slab, the gutter the beam and the down pipe a column, the flow of stress is similar to the flow of water. The amount of water flowing off a sloped roof is far less than the flow in the gutter and down pipe. The same applies to slabs (one-way or two-way) – the flow of force in a slab is far less than the flow of concentrated force in beams and columns. Thus slabs are less susceptible to shear failures (with the exception of punching). Lastly, the closeness of the top and bottom reinforcement limits the crack width, which increases aggregate interlock; therefore the likelihood of shear failure is reduced.

Although most slabs may be classed as thin, many are not. The thickness of silo slabs, for example, may exceed 2 m in depth and may be subjected to extremely high loads. In these types of structures, the l/d ratio is so low that one would question whether or not it should be considered a slab. Deep slabs react similarly to deep beams in that loads are transferred to the supports by arch action.

Distribution of shears in slabs

Yield-line analysis is seen as a useful technique to determine the collapse load of slabs (Johansen 1963). However, the technique extends beyond its traditional application. Yield-lines not only signify the location of maximum principal moments (where yielding occurs), but also the location of zero shears. In a beam, the maximum moment at mid-span is the location of a possible hinge, the point of zero shear as well as the point in which the load sheds to each support. The same is true of slabs. The location of a yield-line is also the location of maximum principal moments, zero shear and the dividing line in which loads are shed. This explains why the slab demarcation lines illustrated in figure 10 of SABS 0100-1 (2000) resemble a yield-line pattern. The answer is simple: they are the same.

It is common knowledge that the maximum shears in slabs exists along the edges. Knowing the pattern and location of zero shears enables one to construct a three-dimensional distribution of shears in a slab. In a beam subjected to UDL, the shear distribution is linear and triangular. In one and two-way slabs, the distribution is similarly linear, but wedge shaped.

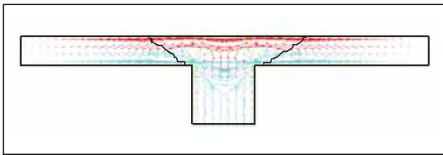

Figure 11 Principal stresses in a section of a flat slab

Punching shear

Point loads on slabs tend to punch through, which is referred to as punching shear (SABS 0100-1 2000; BS 8110: Part 1 1985). A flat slab is also subjected to punching shear at the location of columns. A section of a flat slab is illustrated in figure 11. The stress pattern illustrates the flow of principal tensile and compressive forces in the slab – the pattern is similar to water flowing down a drain.

Also illustrated in figure 11 is a typical punching shear crack in a flat slab. The failure lines are parallel with the compressive trajectories. Tensile splitting forces exist perpendicular to the compressive forces and therefore crack lines are prone to develop in these regions. A close inspection of figure 11 will also indicate that the compressions increase in magnitude closer to the column. Thus failure lines tend to form closer to the column, which is consistent with conventional theory. However, the failure pattern is actually inclined tensile cracking from compressive thrusts rather than punching shear.

A true punching shear failure would cause columns to displace vertically through the slab, similar to the failure shown in figure 12. As observed, several columns of a bridge deck punched through the slab.



Figure 12 Earthquake devastation along Highway 1, California (Photograph by John O'Hara, The Quake of '89)

Vertical shear lines are visible, indicative of shear failure. The picture is a classic example of a true punching shear failure – in this case, the result of an earthquake which hit California in 1989.

CONCLUSIONS

Mysteries associated with shear are generally of our own making. The profession has somehow inherited incorrect nomenclature to describe modes of tension failure. This has led to an incorrect understanding of what shear is and how it affects reinforced concrete. Our lack of understanding may also be attributed to our persistence in matching linear-elastic methods of analysis with ultimate limit state theory. Shear failure rarely occurs in concrete, with the exception of composite construction. Shear failure is a translation failure as opposed to other failure types such as bending, which is rotational (or hinge). What we term a shear failure is actually an inclined tension failure or a splitting failure along a compression thrust. Whatever the case may be, the most

probable cause of cracking in a beam or slab is a result of tension stresses.

The postulates present a series of laws associated with stress. A combination of these laws presents a formal interpretation of shear. Whatever the structural or load configuration may be, the postulates are applicable and present a logical interpretation of crack patterns that we often incorrectly associate with shear.

REFERENCES

- BS 8110: Part 1: 1985. *Structural use concrete*. London: British Standards Institute.
- DePaiva, H A R & Siess, C P 1965 Strength and behaviour of deep beams in shear, *ACSE Proceedings (ST-5)*, Part 1:19.
- Ferguson, P M, Breen, J E, & Jirsa, J O 1988. *Reinforced concrete fundamental*. 5th ed. New York: Wiley.
- Johansen, K W 1963. *Yield-line theory*. Portland Cement Institute.
- ISCE No 3 1984. *Recommendations for the design and construction of steel fiber reinforced concrete*. Tokyo: Japan Society of Civil Engineers.
- Kong, F K & Evans, R H 1987. *Reinforced and prestressed concrete*. 3rd ed. Berkshire: Van Nostrand Reinhold.
- Leonhardt, F 1965. Reducing shear reinforcement in concrete beams and slabs. *Magazine of Concrete Research*, 17(53): 187–198.
- MacGinley, T J & Choo, B S 1985. *Reinforced concrete*. 2nd ed. London: Spon.
- Rowe, R E et al 1985. *Handbook to British Standard BS8110:1985 structural use of concrete*. London: Palladian.
- SABS 0100-1, Ed. 2.2 2000. *The structural use of concrete, Part 1: Design*. Pretoria: South African Bureau of Standards.