



**DRAFT SOUTH AFRICAN STANDARD (DSS):
PUBLIC ENQUIRY STAGE**

Document number SANS 10160-2

Reference 7114/10160-2/DL

Date of circulation 2009-10-13

Closing date 2009-12-15

Number and title:

SANS 10160-2: BASIS OF STRUCTURAL DESIGN AND ACTIONS FOR BUILDINGS AND INDUSTRIAL STRUCTURES — PART 2: SELF-WEIGHT AND IMPOSED LOADS

Remarks:

PLEASE NOTE:

- The technical committee, SABS SC 59I responsible for the preparation of this standard has reached consensus that the attached document should become a South African standard. It is now made available by way of public enquiry to all interested and affected parties for public comment, and to the technical committee members for record purposes. Any comments should be sent by the indicated closing date, either by mail, or by fax, or by e-mail to

SABS Standards Division
Attention: Compliance and Development department
Private Bag X191
Pretoria
0001

Fax No.: (012) 344-1568 (for attention: dsscomments)
E-mail: dsscomments@sabs.co.za

Any comment on the draft must contain in its heading the number of the clause/subclause to which it refers. A comment shall be well motivated and, where applicable, contain the proposed amended text.

- The public enquiry stage will be repeated if the technical committee agrees to significant technical changes to the document as a result of public comment. Less urgent technical comments will be considered at the time of the next amendment.

THIS DOCUMENT IS A DRAFT CIRCULATED FOR PUBLIC COMMENT. IT MAY NOT BE REFERRED TO AS A SOUTH AFRICAN STANDARD UNTIL PUBLISHED AS SUCH.

IN ADDITION TO THEIR EVALUATION AS BEING ACCEPTABLE FOR INDUSTRIAL, TECHNOLOGICAL, COMMERCIAL AND USER PURPOSES, DRAFT SOUTH AFRICAN STANDARDS MAY ON OCCASION HAVE TO BE CONSIDERED IN THE LIGHT OF THEIR POTENTIAL TO BECOME STANDARDS TO WHICH REFERENCE MAY BE MADE IN LAW.

ISBN 978-0-626-

SANS 10160-2:2009

Edition 1

SOUTH AFRICAN NATIONAL STANDARD

SANS 10160: Basis of structural design and actions for buildings and industrial structures

Part 2: Self-weight and imposed loads

Published by SABS Standards Division
1 Dr Lategan Road Groenkloof ☒ Private Bag X191 Pretoria 0001
Tel: +27 12 428 7911 Fax: +27 12 344 1568
www.sabs.co.za
© SABS

SABS

SANS 10160-2:2009

Edition 1

Table of changes

Change No.	Date	Scope

Foreword

This South African standard was approved by National Committee SABS SC 59I, *Construction standards – Basis for the design of structures*, in accordance with procedures of the SABS Standards Division, in compliance with annex 3 of the WTO/TBT agreement.

This edition cancels and replaces the second edition (SABS 0160:1989).

SANS 10160 consists of the following eight parts, under the general title *Basis of structural design and actions for buildings and industrial structures*:

SANS 10160-1, *Basis of structural design*.

SANS 10160-2, *Self-weight and imposed loads*.

SANS 10160-3, *Wind actions*.

SANS 10160-4, *Seismic actions and general requirements for buildings*.

SANS 10160-5, *Basis of geotechnical design and actions*.

SANS 10160-6, *Actions induced by cranes and machinery*.

SANS 10160-7, *Thermal actions*.

SANS 10160-8, *Actions during execution*.

Contents

	Page
Foreword	
1 Scope	
2 Normative references	
3 Definitions and symbols	
3.1 Definitions	
3.2 Symbols	
4 Classification of actions	
4.1 Self-weight	
4.2 Imposed loads	
5 Design situations	
5.1 General	
5.2 Permanent loads	
5.3 Imposed loads	
6 Characteristic values of densities of construction and stored materials	
7 Self-weight of constructed works	
8 Imposed loads on buildings	
8.1 Actions	
8.2 Loads	
8.3 Characteristic values of imposed loads	
8.4 Horizontal loads on parapets, partitions walls and guardrails acting as barriers	
Annex A (informative) Tables for nominal mass density of construction materials, and nominal mass density and angles of repose for stored materials.....	
Bibliography	

SANS 10160-2:2009
Edition 1

This page is intentionally left blank

Draft SA Standard

SANS 10160: Basis of structural design and actions for buildings and industrial structures

Part 2:

Self-weight and imposed loads

1 Scope

1.1 This part of SANS 10160 covers the design guidance and actions for the structural design of buildings. It includes the following:

- a) densities of construction materials and stored materials;
- b) self-weight of construction works; and
- c) imposed loads for buildings.

Where a building or structural member can be expected to be subject to actions not listed in here, the most appropriate information should be used.

1.2 It does not cover design situations and effects of actions in silos and tanks caused by water or other materials.

NOTE In these cases the designer could consult appropriate standards such as EN 1991-4 or specialist literature.

2 NORMATIVE REFERENCES

The following referenced documents are indispensable for the application of this document. All normative documents are subject to revision and, since any reference to a normative document is deemed to be reference to the latest edition of that document, parties to agreement based on this document are encouraged to take steps to ensure the use of the most recent editions of the normative documents indicated below. Information on currently valid national and international standards can be obtained from Standards South Africa.

SANS 10100-1, *The structural use of concrete Part 1: Design.*

SANS 10137, *The installation of glazing in buildings.*

SANS 10160-2:2009

Edition 1

SANS 10160-1, *Basis of structural design.*

SANS 10160-3, *Wind actions.*

SANS 10160-4, *Seismic actions and general requirements for buildings.*

SANS 10160-5, *Basis for geotechnical design and actions.*

SANS 10160-6, *Actions induced by cranes and machinery.*

SANS 10160-7, *Thermal actions.*

SANS 10160-8, *Actions during execution.*

SANS 10162-1, *The structural use of steel Part 1: Limit-state design of hot-rolled steelwork.*

SANS 10162-2, *The structural use of steel Part 2: Limit-states design of cold-formed steelwork.*

SANS 10162-4, *Structural use of steel Part 4: The design of cold-formed stainless steel structural members.*

SANS 10163-1, *The structural use of timber Part 1: Limit-states design.*

SANS 10164-2, *The structural use of masonry Part 2: Structural design and requirements for reinforced and pre-stressed masonry.*

ISO 3898

3 Definitions and symbols

3.1 Definitions

For the purpose of this part of SANS 10160 the following definitions apply:

3.1.1

bulk weight density

the bulk weight density is the overall weight per unit volume of a material, including a normal distribution of micro-voids, voids and pores

NOTE In every day usage this term is frequently abbreviated to “density” (which is strictly mass per unit volume)

3.1.2

angle of repose

the angle of repose is the angle which the natural slope of the sides of a heaped pile of loose material makes to the horizontal

3.1.3

gross weight of vehicle

the gross weight of a vehicle includes the self-weight of the vehicle together with the maximum weight of goods it is permitted to carry

SANS 10160-2:2009

Edition 1

3.1.4

structural element

structural elements comprise the primary structural frame and supporting structures

3.1.5

non-structural elements

non-structural elements are those that include completion and finishing elements connected to the structure, including road surfacing and non-structural parapets. They also include services and machinery fixed permanently to, or within the structure

3.1.6

partitions

partitions are non-load bearing walls

3.1.7

movable partitions

movable partitions are those which can be moved on the floor, be added or removed or re-built at another place

3.2 Symbols

For the purpose of this part of SANS 10160 the following applies :

NOTE The notation used is based on ISO 3898.

Latin upper case letters

A loaded area

A_0 basic area

Q_k characteristic value of variable concentrated load

Latin lower case letters

g_k weight per unit area, or weight per unit length

n number of storeys

q_k characteristic value of a uniformly distributed load

Lower case Greek letters

α_A reduction factor

α_n reduction factor

ρ bulk weight density

SANS 10160-2:2009

Edition 1

φ dynamic magnification factor

ψ_0 factor for combination value of a variable action

ϕ angle of repose (degrees)

4 Classification of actions

4.1 Self-weight

The self-weight of construction works shall be classified as a permanent fixed action (see SANS 10160-1).

4.2 Imposed loads

4.2.1 Imposed loads shall be classified as variable free actions, unless otherwise specified in this standard, (see SANS 10160-1).

4.2.2 When considering the accidental design situation where impact from vehicles or accidental loads from machines may be relevant. These loads shall be taken from SANS 10160-1.

4.2.3 Imposed loads shall be taken into account as quasi-static actions. Such quasi-static load models may include dynamic effects if there is no risk of resonance or other significant dynamic response of the structure. If resonance effects from synchronised rhythmical movement of people or dancing or jumping may be expected, the load model shall be based on special dynamic analysis (see 8.3.1.2).

4.2.4 When considering forklifts and helicopters, the additional loadings due to masses and inertial forces caused by fluctuating effects shall be considered. These effects are taken into account by a dynamic magnification factor, φ , which is applied to the equivalent static load values.

4.2.5 Actions which cause significant acceleration of the structure or structural members shall be classified as dynamic actions and shall be considered using dynamic analysis (see 8.3.1.2).

5 Design situations

5.1 General

The relevant permanent and imposed loads shall be determined for each design situation identified in accordance with SANS 10160-1.

5.2 Permanent loads

5.2.1 The total self-weight of structural and non-structural members shall be taken into account as a single action in a combination of actions.

5.2.2 For areas where it is intended to remove or add structural or non-structural elements, the critical load cases shall be taken into account in the design.

SANS 10160-2:2009

Edition 1

5.2.3 The self-weight of new coatings or distribution conduits (or both), that are intended to be added after execution, shall be taken into account in design situations.

5.2.4 The water level shall be taken into account for the relevant design situations.

5.2.5 The source and moisture content of bulk materials shall be considered in design situations of buildings used for storage purposes.

NOTE The values for the densities provided in Annex A are for materials in the dry state, except if stated otherwise.

5.3 Imposed loads

5.3.1 The total imposed loads, which act simultaneously with other variable actions (for example actions induced by wind, cranes or machinery), shall be taken into account as a single action within a combination of actions.

5.3.2 For areas which are intended to be subject to different categories of loadings, the design shall consider the most critical load case.

5.3.3 Where the number of load variations or the effects of vibrations may cause fatigue, a fatigue load model shall be established.

5.3.4 For structures susceptible to vibrations, dynamic models of imposed loads shall be considered where relevant.

5.3.5 For dynamic loads caused by machinery, actions specified in SANS 10160-6, shall be applied.

5.3.6 The imposed loads to be considered for serviceability limit state verifications, shall be specified in accordance with the service conditions and the requirements concerning the performance of the structure.

6 Characteristic values of densities of construction and stored materials

Characteristic values of densities of construction and stored materials shall be specified. Mean values shall be used as characteristic values.

NOTE Annex A gives mean values for densities and angles of repose for stored materials. When a range is given it is assumed that the mean value will be highly dependent on the source of the material and should be selected considering each individual project.

7 Self-weight of constructed works

7.1 Self-weight of constructed works shall:

- a) be taken into account as a fixed action;
- b) in most cases, be represented by a single characteristic value and be calculated on the basis of the nominal dimensions, as required, and the characteristic values of the densities; and

SANS 10160-2:2009

Edition 1

c) include the structural and non-structural elements including fixed services as well as the weight of earth and ballast.

7.2 Non-structural elements include:

- a) roofing;
- b) surfacing and coverings;
- c) partitions and linings;
- d) hand rails, safety barriers, parapets and kerbs;
- e) wall cladding;
- f) suspended ceilings;
- g) thermal insulation; and
- h) fixed services.

NOTE For information on fixed machinery see SANS 10160-6. For other industrial equipment (e.g. safes) the manufacturer should be consulted.

7.3 Fixed services include:

- a) equipments for lifts and moving stairways;
- b) heating, ventilation and air conditioning equipment;
- c) electrical equipment;
- d) pipes with their content; and
- e) cable trunking and conduits.

7.4 Loads due to movable partitions shall be treated as imposed loads (see 8.3.1.9).

7.5 For manufactured elements such as flooring systems, facades and ceilings, lifts and equipment for buildings, data shall be provided by the manufacturer.

8 Imposed loads on buildings

8.1 Actions

8.1.1 Imposed loads on buildings arise from occupancies such as:

- a) normal use by persons;
- b) furniture and movable objects (e.g. moveable partitions, storage, the contents of containers);

SANS 10160-2:2009

Edition 1

- c) vehicles;
- d) anticipated rare events, such as concentrations of persons or of furniture;
- e) the moving or stacking of objects which may occur during reorganisation or redecoration; and
- f) storage and industrial use.

8.1.2 Imposed loads are modelled by uniformly distributed loads, line loads or concentrated loads or combinations of these loads.

8.1.3 For the determination of imposed loads, the floor and roof areas of the building shall be subdivided into categories according to their use.

8.1.4 Heavy equipment (e.g. in communal kitchens, radiology rooms, boiler rooms) is not covered in this standard and the appropriate floor loads shall be agreed upon between the client or the relevant authority (or both).

8.2 Loads

8.2.1 Floors, beams and roofs

8.2.1.1 For the design of a floor structure within one storey or a roof, the imposed load shall be taken into account as a free action. The appropriately load, uniformly distributed, shall be applied over either the entire area or such part of the area as will produce the most severe effects on the element under consideration.

8.2.1.2 Where the loads on other storeys are relevant, they may be assumed to be distributed uniformly (fixed actions).

8.2.1.3 To ensure a minimum local resistance of the floor structure, a separate verification shall be performed with a concentrated load that, unless stated otherwise, shall not be combined with the uniformly distributed loads or other variable actions.

8.2.1.4 Imposed loads from a single category may be reduced, according to the areas supported by the appropriate member, by a reduction factor α_A (see 8.3.1.10).

8.2.2 Columns and walls

For the design of columns or walls, loaded from several storeys, the total imposed loads on the floor of each storey shall be assumed to be distributed uniformly. The appropriately load, uniformly distributed, shall be applied over either the entire area or such part of the area as will produce the most severe effects on the element under consideration.

8.3 Characteristic values of imposed loads

8.3.1 Residential, social, commercial and administration areas

8.3.1.1 Areas in residential, social, commercial and administration buildings shall be divided into categories according to their specific uses as shown in table 1.

SANS 10160-2:2009

Edition 1

8.3.1.2 Independent of this classification of areas, dynamic effects shall be considered where it is anticipated that their occupancy will cause significant dynamic effects (see 4.2.3 and 4.2.5).

8.3.1.3 The loaded areas for categories, as specified in Table 1, shall be designed by using characteristic values q_k (uniformly distributed load) and Q_k (concentrated load). The characteristic load q_k is intended for the determination of general effects and Q_k for the determination of local effects.

8.3.1.4 The characteristic values for q_k and Q_k are minimum values and shall be increased in the design where necessary.

8.3.1.5 The loads q_k and Q_k shall not be applied simultaneously.

8.3.1.6 For concentrated loads, which arise from storage racks or from lifting equipment, Q_k shall be determined for the individual case (see 8.3.2).

8.3.1.7 The concentrated load shall be considered to act at any point on the floor, balcony or stairs.

8.3.1.8 Where floors are subject to multiple use, they shall be designed for the most unfavourable category of loading which produces the highest effects of actions (e.g. forces or deflection) in the member under consideration.

8.3.1.9 Provided that a floor allows a lateral distribution of loads, the self-weight of movable partitions may be taken into account by a uniformly distributed load q_k which shall be added to the imposed loads for floors obtained from Table 1.

The uniformly distributed loads are as follows:

- a) $q_k = 0,5 \text{ kN/m}^2$ for movable partitions with a self-weight $\leq 1,0 \text{ kN/m}$ wall length;
- b) $q_k = 0,8 \text{ kN/m}^2$ for movable partitions with a self-weight $\leq 2,0 \text{ kN/m}$ wall length; and
- c) $q_k = 1,2 \text{ kN/m}^2$ for movable partitions with a self-weight $\leq 3,0 \text{ kN/m}$ wall length.

For heavier partitions, account shall be taken of:

- a) the location and directions of the partitions; and
- b) the structural form of the floors.

8.3.1.10 In accordance with 8.2.1.4 a reduction factor α_A may be applied to the q_k values for imposed loads in Table 1 for floors and Table 5 for accessible roofs.

8.3.1.11 Where the loaded area of a floor, which is supported by a column or bearing wall (the cumulative area of all floors so supported being taken), or by a single span of a beam or girder, or by a single panel of a slab (solid or ribbed), or flat-plate, the distributed loading may, for the design of the building or part of the building, be multiplied by a reduction factor α_A equal to:

SANS 10160-2:2009

Edition 1

a) For occupancy categories A and B (Table 1) :

$$\alpha_A = 0,3 + \frac{3,1}{\sqrt{A}} \geq 0,5 \quad (1)$$

where

A is the loaded floor area exceeding 20 m²

b) For occupancy categories C and D (table 1) :

$$\alpha_A = 0,5 + \frac{4,5}{\sqrt{A}} \geq 0,7 \quad (2)$$

where

A is the loaded floor area exceeding 80 m²

8.3.1.12 For a) as well as b) the following applies:

- a) for one-way spanning slabs, the width of the loaded area, for the purpose of calculating the reduction factor α_A , does not exceed one half of the span of such slab;
- b) for rectangular two-way spanning slabs, the loaded area, for the purpose of calculating the reduction factor α_A , does not exceed that of a square of sides equal to the smaller dimension of the rectangle.

SANS 10160-2:2009
Edition 1

Table 1 — Imposed loads on floors, balconies and stairs in buildings

1	2	3	4	5	6
Category	Specific use	Sub-category	Example	q_k kN/m ²	Q_k kN
A	Areas for domestic and residential activities	A1	All rooms in a dwelling unit and a dwelling house, including corridors and lobbies.	1,5	1,5
		A2	Bedrooms, wards, dormitories, private bathrooms and toilets in hospitals, hotels, hostels and other institutional residential occupancies.	2,0	1,5
		A3	Stairs and escape routes in residential occupancies for example, serving hospitals, hotels, hostels and other institutional residential occupancies.	3,0	1,5
		A4	Balconies accessible to domestic and residential occupancy areas.	4,0	3,0
B	Public areas (not susceptible to crowding)	B1	Office areas for general use.	2,5	4,5
		B2	Public libraries, excluding stack areas.	3,0	4,5
		B3	Kitchens, communal bathrooms and toilets in educational buildings, hotels, office buildings and other institutional occupancies.	3,0	5,0
		B4	Light laboratories, operating theatres, X-ray rooms.	3,0	5,0
		B5	Filing and office storage areas, stack areas in libraries and archives.	2,5 per m stack height, but $\geq 5,0$	5,0
C	Public areas where people may congregate (with the exception of areas defined under category A, B and D)	C1	Areas with movable furniture, tables etc. e.g. class rooms, areas in schools, cafés, restaurants, dining halls, reading rooms, reception areas, banking halls.	3,0	5,0
		C2	Areas with fixed seats, e.g. areas in churches, theatres or cinemas, conference rooms, lecture halls, assembly halls, waiting rooms, railway waiting rooms; grandstands with fixed individual seating.	4,0	3,0
		C3	Areas without obstacles for moving people, all without fixed individual seating e.g. assembly halls and areas, sport complexes, grandstands, areas in museums, exhibition rooms, etc. and access areas in public and administration buildings, hotels, hospitals, airports, railway station forecourts and terminals; stairs, corridors, landings; cantilever balconies accessible to the public.	5,0	3,0

SANS 10160-2:2009
Edition 1

Table 1 (Concluded)

1	2	3	4	5	6
Category	Specific use	Sub-category	Example	q_k kN/m ²	Q_k kN
		C4	Areas with possible physical activities, e.g. dance halls, gymnastic rooms, stages.	5,0	5,0
		C5	Areas susceptible to large crowds, e.g. in buildings for public events like concert halls, exhibition halls, sports halls including stands, terraces, access areas, escape routes and railway platforms.	5,0	5,0
D	Shopping areas	D	Areas in general retail shops and department stores.	5,0	5,0

NOTE 1 Depending on their anticipated uses, areas likely to be categorised as C2, C3, C4 may be categorised as C5 by decision of the client or the relevant authority.

NOTE 2 See 8.3.2 for storage or industrial activity.

NOTE 3 The concentrated load Q_k is to be applied over an area of 0,1 m x 0,1 m.

NOTE 4 Escape routes for category B and D shall be designed according to category C5.

NOTE 5 See 8.3.1.9 for loads due to movable partition for categories B and C.

8.3.2 Areas for industrial activities and storage

8.3.2.1 General actions

8.3.2.1.1 Loads in industrial areas shall be assessed considering the intended use and the equipment which is to be installed, including:

- a) the weight of the plant;
- b) the weight of the heaviest pieces under treatment or the weight of the maximum volume of the product being processed;
- c) the weight of gangways and working platforms;
- d) the weight of handling equipment; and
- e) loads resulting from necessary maintenance or replacement of stationary plant.

8.3.2.1.2 Make provision, where necessary, for the influence of dynamic forces arising from operations with dynamically imbalanced equipment, from the shifting of heavy loads over the floor, or from falling or suddenly displaced goods in storage.

8.3.2.1.3 Areas for storage and industrial activities shall be divided into three categories E1 to E3 (see table 2).

SANS 10160-2:2009

Edition 1

8.3.2.1.4 Access ladders and walkways shall be loaded in accordance with category E4 (see table 2).

8.3.2.1.5 The categorized loaded areas as specified in table 2, shall be designed by using characteristic values q_k (uniformly distributed load) and Q_k (concentrated load).

8.3.2.1.6 Minimum recommended values for q_k and Q_k are given in table 2. The values may be changed if necessary according to the usage for the particular project. The characteristic load q_k is intended for determination of general effects and Q_k for local effects and shall not be applied simultaneously.

Table 2 — Imposed loads on floors due to industrial use and storage

1	2	3	4	5
Category	Specific Use	Example	q_k kN/m ²	Q_k kN
E1	Light industrial use	Production rooms such as workshops with lightweight equipment (< 5 kN each).	3,0	5,0
E2	Industrial use	Production rooms such as workshops in works and factories.	5,0	5,0
E3	Areas susceptible to accumulation of goods, including access areas	Areas for storage use including storage of books and other documents.	2,5 per m stack height, but $\geq 5,0$	5,0
E4	Access ladders and walkways	Maintenance walkways in buildings.	1,5	1,5

8.3.2.1.7 The characteristic value of the imposed load shall be the maximum value taking into account the dynamic effects if appropriate. The loading arrangement shall be so defined that it produces the most unfavourable conditions allowed in use.

8.3.2.1.8 The loads for transient design situations due to installation and reinstallation of machines, and production units, shall be determined in accordance with SANS 10160-6.

8.3.2.1.9 The characteristic values of vertical loads in storage areas shall be derived from the density and the upper design values for stacking heights.

NOTE 1 See annex A for densities of materials.

NOTE 2 When stored materials exert horizontal forces on walls etc., the horizontal force may be determined in accordance with an appropriate Standard, for example EN 1991-4.

8.3.2.1.10 Loads for storage areas for books and other documents shall be determined from the loaded area and the height of the book cases using appropriate values for density.

SANS 10160-2:2009
Edition 1

8.3.2.2 Actions induced by forklifts

8.3.2.2.1 Forklifts shall be classified in 6 classes FL1 to FL6 depending on the net weight, dimensions and hoisting loads, see table 3.

8.3.2.2.2 The static vertical axle load Q_k of a forklift depends on the forklift classes FL1 to FL6 and shall be obtained from table 3.

Table 3 — Axle loads of forklifts according to classes FL

1	2	3	4	5	6	7
Class of forklift	Net weight	Hoisting load	Width of axle	Overall width	Overall length	Axle load
	kN	kN	a m	b m	L m	Q_k kN
FL1	21	10	0,85	1,00	2,60	26
FL2	31	15	0,95	1,10	3,00	40
FL3	44	25	1,00	1,20	3,30	63
FL4	60	40	1,20	1,40	4,00	90
FL5	90	60	1,50	1,90	4,60	140
FL6	110	80	1,80	2,30	5,10	170

NOTE 1 The minimum acceptable loads caused by forklifts are given for design. For specific requirements loads may be based on information obtained from the manufacturer of the forklift.

NOTE 2 If the net weight exceeds 110 kN or the hoisting load exceeds 80 kN, the axle loads should be obtained from the manufacturer of the fork lift.

8.3.2.2.3 Actions due to forklifts shall be considered as concentrated loads according to Table 3, acting together with the appropriately imposed distributed loads given in Table 1 and Table 2.

8.3.2.2.4 The static vertical axle load Q_k shall be increased by the dynamic factor using equation (3):

$$Q_{k,dyn} = \varphi Q_k \tag{3}$$

where

$Q_{k,dyn}$ is the dynamic characteristic value of the action;

φ is the dynamic magnification factor;

Q_k is the static characteristic value of the action.

8.3.2.2.5 The dynamic factor φ for forklifts takes into account the inertial effects caused by acceleration and deceleration of the hoisting load and shall be taken as :

$\varphi = 1,4$ for pneumatic tyres; and

SANS 10160-2:2009
Edition 1

$\varphi = 2,0$ for solid rubber tyres.

8.3.2.2.6 For forklifts having a net weight > 110 kN, the loads shall be determined by a more accurate analysis.

8.3.2.2.7 The vertical axle load Q_k and $Q_{k,dyn}$ of a forklift shall be arranged according to Figure 1.

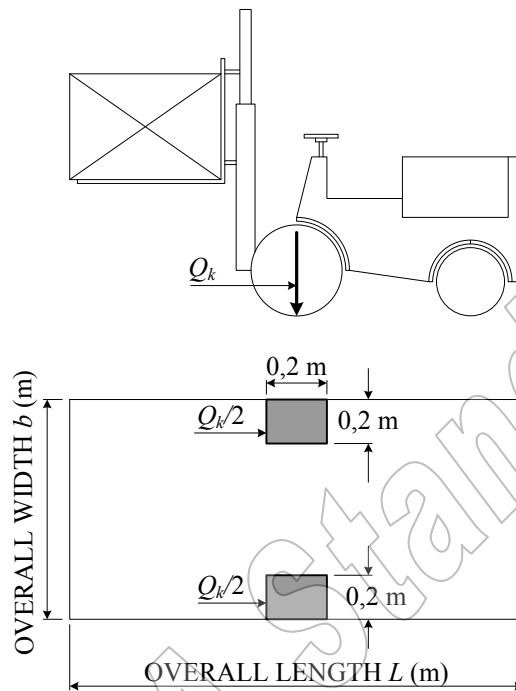

Figure 1 — Dimensions for forklifts

8.3.2.2.8 Horizontal loads due to acceleration or deceleration of forklifts may be taken as 30 % of the vertical axle loads Q_k .

NOTE Dynamic factors need not be applied to the horizontal loads.

8.3.2.3 Actions induced by transport vehicles on structures

8.3.2.3.1 The actions from transport vehicles that move on floors freely or guided by rails shall be determined by a pattern of wheel loads.

NOTE Floors consisting of slabs on the ground are excluded.

8.3.2.3.2 The static values of the vertical wheel loads shall be given in terms of permanent weights and pay loads. Their spectra shall be used to define combination factors and fatigue loads. (See SANS 10160-1)

8.3.2.3.3 The vertical and horizontal wheel loads shall be determined for the specific case.

8.3.2.3.4 The load arrangement including the dimensions relevant for the design shall be determined for the specific case.

SANS 10160-2:2009

Edition 1

8.3.2.3.5 Actions due to transport vehicles shall be considered as concentrated loads acting together with the appropriately imposed distributed loads given in table 1 and table 2.

8.3.2.4 Actions induced by special devices for maintenance

8.3.2.4.1 Special devices for maintenance shall be modelled as loads from transportation vehicles, (see 8.3.2.3).

8.3.2.4.2 The load arrangements including the dimensions relevant for the design shall be determined for the specific case.

8.3.2.4.3 In the case of additional loadings on roof trusses or other members in buildings containing industrial and storage occupancies, ensure that where a roof truss (or any of its elements) or any other member is designed to sustain a specific load at a specific location, such location shall be clearly identified by a suitable hook, shackle or similar device, and the capacity shall be clearly indicated.

8.3.3 Garages and vehicle traffic areas (excluding bridges)

8.3.3.1 Traffic and parking areas in buildings shall be divided into two categories according to their accessibility for vehicles as shown in table 4.

8.3.3.2 The load model, which shall be used, is a single axle with a load Q_k and a uniformly distributed load q_k . The characteristic values for q_k and Q_k are given in Table 4.

The characteristic load q_k is intended for determination of general effects and Q_k for local effects and these loads shall not be applied simultaneously.

Table 4 — Imposed loads on traffic and parking areas in buildings

1	2	3	4	5
Categories of traffic areas	Specific use	Examples	q_k kN/m ²	Q_k kN
F	Traffic and parking areas for light vehicles of (≤ 25 kN gross vehicle weight)	Garages, parking areas, parking halls.	2,0	15
G	Traffic and parking areas for medium vehicles (> 25 kN, ≤ 160 kN gross vehicle weight, on 2 axles)	Access routes; delivery zones; zones accessible to fire engines (≤ 160 kN gross vehicle weight)	5,0	90

NOTE 1 Access to areas designed to category F should be limited by physical means built into the structure.
 NOTE 2 Areas designed to categories F and G should be posted with the appropriate warning signs.
 NOTE 3 Where access by vehicles with a gross vehicle weight > 160 kN is possible, an appropriate code of practice describing traffic loads should be used.

SANS 10160-2:2009

Edition 1

8.3.3.3 For vehicles with a gross weight of between 25 kN and 160 kN, the values of q_k and Q_k can only be interpolated provided that the necessary measures are in place to limit gross vehicle weight to the value provided for.

8.3.3.4 The axle load shall be applied on two square surfaces as shown in figure 2, in positions that will produce the most adverse effects.

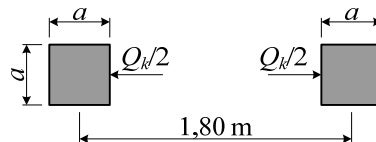

NOTE For Category F: $a = 100\text{ mm}$
for Category G: $a = 200\text{ mm}$

Figure 2 — Dimensions of axle load

8.3.4 Roofs

8.3.4.1 Roofs shall be categorised according to their accessibility into four categories as shown in table 5.

8.3.4.2 Imposed loads for roofs of category H shall be those given in table 5. These are primarily maintenance or construction loads intended to represent the effects of workmen or stacked materials, etc. Alternatively, the distributed load will cater for limited accumulation of snow, hail or rainwater on roofs (approximately 250 mm depth of snow, 60 mm of hail or 50 mm of rainwater, measured vertically).

8.3.4.3 The possibility that gutters and down pipes may be blocked, causing ponding and the accumulation of rainwater, must be taken into account in the determination of the imposed load.

8.3.4.4 Where it is known that hail of depth exceeding 60 mm could be expected to accumulate on a roof, a distributed load corresponding to the expected depth of hail must be applied.

8.3.4.5 Where it is known that snow of depth exceeding 250 mm could be expected to accumulate on a roof, a distributed load corresponding to the expected depth of snow shall be applied.

8.3.4.6 For roofs of category H the minimum characteristic values q_k and Q_k that shall be used are given in table 5. The load q_k is related to the projected area of the roof under consideration.

8.3.4.7 The minimum values given in table 5 do not take into account uncontrolled accumulations of construction materials that may occur during maintenance.

NOTE See also SANS 10160-8 for actions during execution.

SANS 10160-2:2009
Edition 1

Table 5 — Imposed loads on roofs (minimum values)

1	2	3	4	5
Category	Specific use	Example	q_k kN/m ²	Q_k kN
H	Inaccessible roofs	H1 Inaccessible roofs during construction ^{a)}	0,75 for $A \leq 3 \text{ m}^2$ 0,25 for $A \geq 15 \text{ m}^2$	1,0 over an area of 0,1 m x 0,1 m
		H2 For normal maintenance and repair ^{a)}	0,50 for $A \leq 3 \text{ m}^2$ 0,25 for $A \geq 15 \text{ m}^2$	1,0 over an area of 0,1 m x 0,1 m
J	Accessible flat roofs	Where access is provided in addition to access necessary for maintenance, excluding occupancy according to categories A to D	2,0	2,0 over an area of 0,1 m x 0,1 m
K	Accessible flat roofs	Where access is provided according to occupancy categories A to D.	As per Tables 1, 2 and 4 according to the specific use	
L	Roofs accessible for special services	Helicopter landing areas	Not applicable	see Table 6
^{a)} Where A is the loaded area for the member under consideration or the area of the roof slab confined by the perimeter of supporting members, measured on plan in m ² . For a loaded area of between 3 m ² and 15 m ² the following interpolation formula shall be used : For category H1 : $q_k = \left(0,25 + \frac{15 - A}{24} \right)$ For category H2 : $q_k = \left(0,25 + \frac{15 - A}{48} \right)$				

8.3.4.8 For roofs separate verifications shall be performed for the concentrated load Q_k and the uniformly distributed load q_k , which shall not be applied simultaneously.

8.3.4.9 The following loads shall be used for the design of frames and coverings of access hatches (other than glazing), the supports of ceilings and similar structures:

- a) without access: no imposed load;
- b) with access: 0,25 kN/m² distributed over the whole area supported, and the concentrated load of 1,0 kN placed so as to produce maximum stresses in the affected member.

8.3.4.10 For roofs of category L, the actions from helicopters on landing areas shall be determined in accordance with table 6.

8.3.4.11 For helicopters with intermediate take-off load Q , the value of Q_k could be interpolated between values for HC1 and HC2 only on the condition that the necessary measures are in place to limit the take-off load Q to the value provided for.

SANS 10160-2:2009
Edition 1

Table 6 — Imposed loads on roofs of category L for helicopters

1	2	3	4
Class of helicopter	Take-off load of helicopter Q kN	Q_k kN	Dimensions of loaded area m
HC1	$Q \leq 20$	20	0,2 x 0,2
HC2	$20 < Q \leq 60$	60	0,3 x 0,3
NOTE The dynamic factor to be applied to the load Q_k to take account of impact effects may be taken as $\varphi = 1,4$.			

8.4 Horizontal loads on parapets, partitions walls and guardrails acting as barriers

8.4.1 The characteristic values of loads on parapets, railings, balustrades and walls acting as barriers, including partition walls, exterior walls, curtain walls and glazing units are specified in 8.4.

8.4.2 The characteristic values of the line load q_k acting at the height of the partition wall or parapets but not higher than 1,20 m shall be taken from Table 7.

8.4.3 The characteristic loads q_k and Q_k shall not be applied simultaneously.

8.4.4 For guardrails in elevated or multi-storey parking garages for vehicles of a gross weight not exceeding 25 kN: a horizontal load of 30 kN, distributed over any 1,5 m length of barrier, acting normal to the barrier and at a height of 550 mm above floor level shall be applied.

NOTE Actions due to impact by vehicles for all categories of traffic areas, see Table 4, shall be considered as an accidental load in accordance with SANS 10160-6.

8.4.5 Boundary, yard and garden walls shall be designed in accordance with category A in Table 7.

SANS 10160-2:2009
Edition 1

Table 7 — Horizontal loads on partition wall and parapets

1	2	3
Category	q_k kN/m	Q_k kN
A, B and C1	0,5	1,0
C2 – C4	1,5	1,0
C5	3,0	1,0
D	1,5	1,0
E	1,0	1,0

NOTE 1 For description of categories A to D see Table 1 and for description of category E see Table 2.
NOTE 2 For areas of category E the horizontal loads depend on the occupancy. Therefore the value of q_k is defined as a minimum value and should be checked for the specific occupancy.
NOTE 3 A concentrated force Q_k should be applied acting in any direction between vertically downward and horizontally inward or outward, applied over a 100 mm length for beam elements and over a 100 mm x 100 mm area for plate elements and acting at the top or any other position of the guard for all categories.

8.4.6 Ensure that all walls, curtain walls, partitions, balustrades and all large glazed areas within one metre of the floor that may be exposed to impact from a person falling against or bumping into them, have a level of impact resistance which will prevent undue risk of injury including the prevention of the person from falling through a balustrade, resulting from failure, fracture or penetration of the wall, partition, curtain wall, glazed panel or balustrade.

8.4.7 Resistance to impact will be proven by testing using an impact of 400 J delivered by means of a 250 mm diameter bag filled with dry sand to a mass of 30 kg, representative of the most severe conditions likely to occur. The impact test may be reduced to 200 joules for instances where the perpendicular approach distance is less than 1.5 metres.

NOTE 1 refer to SANS 1263:Part 1 “Safety and security glazing materials for buildings Part 1 : Safety performance of glazing materials under human impact” for an impactor capable of greater uniformity of impact and of delivering impacts up to and exceeding 400 joules.

NOTE 2 For non-brittle materials and for masonry, the ability to withstand the forces specified in Paragraph 8.4 with the normal resistance factors for the materials concerned will generally ensure adequate resistance to human impact.

NOTE 3 the approach distance limits the velocity and therefore the impact energy of a person and this is reduced where approach distances are small, such as on narrow staircases or corridors. If a door is positioned opposite such a barrier then the approach distance will increase and if this exceeds 1.5 metres then the higher impact energy of 400 joules must be used. If non load bearing systems such as dry wall partitions are installed and conceivably the position of doors or openings adjacent to the barrier may be changed that affect approach distance then the higher impact energy of 400 joules must be used.

NOTE 1 It is recommended that the installation be verified in its final position to ensure that connections to support work and levels of onsite workmanship allow the design to meet impact performance requirements.

SANS 10160-2:2009

Edition 1

8.4.8 Where materials are to be stored against a wall or partition in such a manner that a horizontal thrust is transmitted to such wall or partition, the designer must ensure that due allowance is made for such thrust in the design procedure. (see 8.3.2.1.8).

Draft SA Standard

SANS 10160-2:2009
Edition 1

Annex A
(Informative)

Tables for nominal mass density of construction materials, and nominal mass density and angles of repose for stored materials

Table A.1 — Density of concrete, mortar and plaster

1	2	3
Materials		Mass density
Type	Composition	ρ kN/m ³
Mortar	cement mortar	19,0 – 23,0
	gypsum mortar	15,0 – 18,0
	lime-cement mortar	18,0 – 20,0
	lime mortar	12,0 – 19,0
Plaster	cement and sand	23,0
	gypsum	17,0
	lightweight vermiculite	8,0
Reinforced concrete	nominal	24,0 ^{a)}
	2% reinforcement	25,0 ^{a)}
	3% reinforcement	26,0 ^{a)}
Special heavyweight concrete	natural heavy aggregate	36,0 ^{a)}
	steel shot aggregates	52,0 ^{a)}
Un-reinforced concrete	nominal	23,0 ^{a)}
	broken brick aggregate	20,0 ^{a)}
	lightweight aggregate	15,0 ^{a)}

^{a)} Increase mass density by 1 kN/m³ for unhardened concrete.

SANS 10160-2:2009
Edition 1

Table A.2 — Density of masonry materials

1	2	3
	Construction materials	Mass density
Type	Composition	ρ kN/m ³
Masonry units	• burnt clay masonry units, non-facing, plastered	19,0
	• burnt clay masonry units, facing	23,0
	• calcium silicate masonry units	20,0
	• natural aggregate concrete masonry units, solid	22,0
	• natural aggregate concrete (density 22,0 kN/m ³) masonry units, hollow with 25% to 60% voids	8,8 - 16,5
	• lightweight aggregate concrete masonry units, solid	18,0
	• lightweight aggregate concrete (density 18 kN/m ³) • masonry units, hollow with 25% to 60% voids	7,2 - 13,5
	refractory masonry units	12,0
	• aerated concrete masonry units, solid	8,0 - 12,0
	• terra cotta	21,0
Natural stones	• granite, syenite, porphyry	27,0 - 30,0
	• basalt, diorite, gabbro	27,0 - 31,0
	• tachylite	26,0
	• basaltic lava	24,0
	• gray wacke, sandstone	21,0 - 27,0
	• dense limestone	20,0 - 29,0
	• other limestone	20,0
	• volcanic rock	20,0
	• gneiss	30,0
	• slate	28,0
• stone rubble, packed	22,0	
• quarry waste	15,0	
• hardcore, consolidated	19,0	

SANS 10160-2:2009
Edition 1

Table A.3 — Density of flooring materials

1	2	3
Product	Type or composition	Mass density ρ kN/m ³
Flooring	clay floor tiles, including screed	44,0
	granolithic, terazzo	23,0
	concrete paving slabs, precast	24,0
Floor coverings	flexible PVC	16,0
	rubber	17,0
	fibre vinyl	22,0

Table A.4 — Density of timber and timber products

1	2	3
Type or product	Species or composition	Mass density ρ kN/m ³
South African structural timber	up to grade S5 and S7	5,0
	up to grade S10	7,0
Imported structural timber	structural pitch pine	6,7
	douglas fir	5,5
Wood finishing	Iroko	6,5
	Mahogany	5,9
	Meranti	8,9
	Sapele	6,2
	Teak	6,6
Timber boarding	blockboard	5,0
	chipboard	7,0
	fibreboard	3,0
	hardboard, dense	11,0
	hardboard, medium	8,0
	plywood	6,0
Floorboarding and blocks	softwood	5,0
	hardwood	8,0
Pulp (wood)	unspecified	7,5

SANS 10160-2:2009
Edition 1

Table A.5 — Density of metals

1	2
Type of metal	Mass density ρ kN/m ³
Aluminium	28,0
Brass	85,0
Bronze	89,0
Copper, cast	87,0
Copper, wrought	89,0
Iron, cast	72,0
Iron, wrought	77,0
Lead	113,0
Steel	78,0
Stainless steel	79,0
Zinc, rolled	71,0

Table A.6 — Density of sundry building materials

1	2	3
Materials	Composition	Mass density ρ kN/m ³
Glass	broken sheets	22,0
		25,0
	glass reinforced products (GRP)	2,0
Cork	cork, granular	1,6
	cork, compressed	3,5
Macadam	waterbound	26,0
	tarmacadam	23,0
	asphalt	22,0
Plastics	acrylic sheet	12,0
	PVC products	17,0
Insulating materials	expanded polystyrene foam	0,3
	insulating felt	2,0
	foamed polyurethane	1,0
	glass fibre mat	0,4
	woodwool	0,6

SANS 10160-2:2009
Edition 1

Table A.7 Stored materials — Building and construction

1	2	3	4
Materials	Type or composition	Mass density ρ kN/m³	Angle of repose φ degrees
Concrete aggregates	lightweight	9,0 – 20,0	30
	normal	20,0 – 30,0	30
	heavyweight	>30,0	30
	gravel and sand, bulked	15,0 – 20,0	35
	sand	14,0 – 19,0	30
	crushed bricks	15,0	35
Blast furnace slag	coarse clinker, expanded clay	7,0	35
	fine clinker, expanded clay	10,0	30
Blast furnace slag	lumps	17,0	40
	granules	12,0	30
	crushed foamed	9,0	35
Vermiculite	exfoliated, aggregate for concrete	1,0	–
	crude	6,0 – 9,0	–
Bentonite	loose	8,0	40
	shaken down	11,0	-
Cement	in bulk	16,0	28
	in bags	15,0	-
Additives	fly ash	10,0 – 14,0	25
	gypsum powder	15,0	25
	lignite filter ash	15,0	20
	lime	13,0	25
	limestone powder	13,0	25 – 27
	magnesite powder	12,0	-
Plastics	polyethelene, polystyrol granulated	6,4	30
	polyvinylchloride powder	5,9	40
	polyester resin	11,8	-
	adhesive resin	13,0	-
Water	fresh	10,0	-
	sea water	10,5	-

SANS 10160-2:2009
Edition 1

Table A.8 —Stored products - Agricultural

1	2	3	4
Products	Type or composition	Mass density ρ kN/m ³	Angle of repose φ degrees
Fertiliser, artificial	NPK, granulated	8,0 – 12,0	25
	basic slag, crushed	13,7	35
	phosphates, granulated	10,0 – 16,0	30
	potassium sulphate	12,0 – 16,0	28
	urea	7,0 – 8,0	24
Fodder	green, loosely stacked	3,5 – 4,5	-
Grain (<14% moisture content)	whole grain	7,8	30
	barley	7,0	30
	brewer's grain (wet)	8,8	-
	herbage seeds	3,4	30
	maize in bulk	7,4	30
	maize in bags	5,0	-
	oats	5,0	30
	oilseed rape	6,4	25
	rye	7,0	30
	wheat in bulk	7,8	30
wheat in bags	7,5	-	
Hay	baled	1,0 – 3,0	-
	rolled bales	6,0 – 7,0	-
Hides and skin	unspecified	8,0 – 9,0	-
Hops	unspecified	1,0 – 2,0	25
Malt	unspecified	4,0 – 6,0	20
Meal	ground	7,0	45
	cubes	7,0	40
Peat	dry, loose, shaken down	1,0	35
	dry, compressed in bales	5,0	-
	wet	9,5	-
Silage	unspecified	5,0 – 10,0	-
Straw	in bulk, dry	0,7	-
	baled	1,5	-
Tobacco	in bales	3,5 – 5,0	-
Wool	in bulk	3,0	-
	baled	7,0 – 13,0	-

SANS 10160-2:2009
Edition 1

Table A.9 — Stored products – Foodstuffs

1	2	3	4
Products	Type or composition	Mass density ρ kN/m ³	Angle of repose φ degrees
Eggs,	in stands	4,0 – 5,0	-
Flour	bulk	6,0	25
	bagged	5,0	-
Fruit	Apples, loose	8,3	30
	Apples, boxed	6,5	-
	Cherries	7,8	-
	pears	5,9	-
	raspberries, in trays	2,0	-
	strawberries, in trays	1,2	-
	tomatoes	6,8	-
Sugar	loose, piled	7,5 – 10,0	35
	dense and bagged	16,0	-
Vegetables (green)	cabbages	4,0	-
	lettuce	5,0	-
Vegetables (legumes)	beans, general	8,1	35
	peas	7,8	-
Vegetables (roots)	general	8,0	-
	beetroot	7,4	40
	carrots	7,8	35
	onions	7,0	35
	turnips	7,0	35
Potatoes	in bulk	7,6	35
	in boxes	4,4	-
Sugarbeet	dried and chopped	2,9	35
	raw	7,6	-
	wet shreds	10,0	-

SANS 10160-2:2009
Edition 1

Table A.10 — Stored products – Solid fuels

1	2	3	4
Products	Type or composition	Mass density ρ kN/m ³	Angle of repose φ degrees
Charcoal	air-filled	4,0	-
	air-free	15,0	-
Coal	block briquettes, tipped	8,0	35
	block briquettes, stacked	13,0	-
	egg briquettes	8,3	30
	coal, raw from pit	10,0	35
	coal dust	7,0	25
	coke	4,0 – 6,5	35 + 45
Firewood	all other kinds of coal	8,3	30 - 35
	unspecified	5,4	45
Lignite, brown coal	briquettes, tipped	7,8	30
	briquettes, stacked	12,8	-
	damp	9,8	35 - 40
	dry	7,8	35
	dust	4,9	25 - 40
Peat	black, dried, firmly packed	6,0 – 9,0	-
	black, dried, loosely tipped	3,0 – 6,0	45

SANS 10160-2:2009
Edition 1

Table A.11 — Stored products – Liquids

1	2	3
Products	Type or composition	Mass density ρ kN/m ³
Beverages	beer, bulk	10,0
	beer, bottles in cases	4,5
	beer, in barrels	5,5
	milk	10,0
	wine, bulk	10,0
	wine, bottles in cases	6,0
Natural oils	castor oil	9,3
	glycerol (glycerine)	12,3
	linseed oil	9,2
	olive oil	8,8
Organic liquids and acids	alcohol	7,8
	ammonium	9,0
	ether	7,4
	hydrochloric acid (40% by weight)	11,8
	methylated spirit	7,8
	nitric acid (91% by weight)	14,7
	sulphuric acid (30% by weight)	13,7
sulphuric acid (87% by weight)	17,7	
	turpentine, white spirit	8,3
Hydrocarbons	aniline	9,8
	benzene (benzol)	8,8
	coal tar	10,8 – 12,8
	creosote	10,8
	naphtha	7,8
	paraffin (kerosene)	8,3
	petroleum oil	9,0
	benzine	6,9
	oil, crude	9,8 – 12,8
	diesel	8,3
	lubricating oil	8,8
	petrol (gasolene)	7,4
liquid gas, butane	5,7	
liquid gas, propane	5,0	
turpentine	8,5	
Other liquids	mercury	133,0
	red lead paint	59,0
	white lead, in oil	38,0
	sludge, over 50 % by volume water	10,8

SANS 10160-2:2009
Edition 1

Bibliography

EN 1991-4, *Actions on structures – Part 4: Silos and tanks.*

SANS 1263-1, *Safety and security glazing materials for buildings Part 1: Safety performance of glazing materials under human impact.*

© SABS

Draft SA Standard